

Size range: 2" - 12"



Profit butterfly valves type WBV are indicating valves. The wafer type body has vulcanised full face rubber gaskets and is installed between flanges. The valves are designed to be used in fire protection sprinkler systems and HVAC systems.

Characteristics

- Indoor use.
- Manually operated with external gearbox with open/close directions on handwheel.
- Yellow open / close position indicator.
- Two built-in micro-switches, pre-wired.
- One of the switches is activated before the handwheel has rotated 2 full turns from the fully OPEN position.
- The second switch is activated before the handwheel has rotated 2 full turns from the full CLOSED position (bypass application).
- Valve body features 4 bolt-holes for easy mounting.
- F/F dimension comply with EN 558/series20 and ASME B16.10/narrow.
- Installation between flange-types EN 1092/PN10/PN16 and ASTM B16.5 Class 150/Class125.
- Anti-corrosion protection: high grade polyester powder coating, RAL 3000, meets or exceed AWWA C550 standards.
- Recommended max. flow velocity = 5m/sec.
- In compliance with EN 593.

Working pressure

20,7 barg / 300 psi

Working temperature

+1°C to +80°C

Approvals

- FM approved to FM standard 1112
- CNPP certified

Material specifications

Handweel with chain and lock.

Component	Specification	European standard	ASTM standard
Body	Ductile cast iron	EN-GJS-450-10	A 536 gr 65-45-12
Gearbox housing	Grey cast iron	EN-GJL-250	A 126 Class B
Disc	Ductile cast iron	EN-GJS-450-10	A 536 gr 65-45-12
Seat	EPDM rubber	/	D2000
Fasteners	Carbon steel	Gr 4.6	A 307 Gr B
Bushing	Brass	2.038	B 124 C 37700
Shaft	Stainless steel	1.4057	A 276 grade 431
Micro-switch (2x)	VS10 N0 21C2	/	/

Dimensions

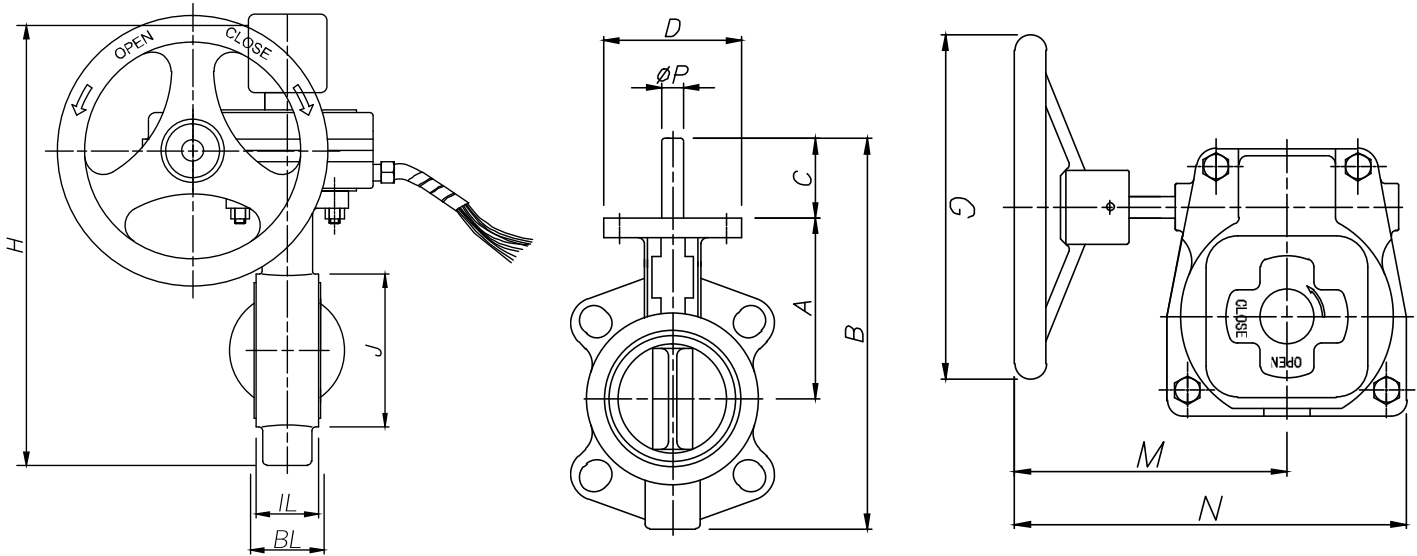

Dimensions (mm)														
Size	IL*	BL*	A	B	C	D	E	F	G	H	J	M	N	P
2"	43	48	110	236	52	90	65	190	115	304	93	150	228	14
2,5"	46	51	118	255	52	90	65	190	115	323	110	150	228	14
3"	46	52	130	277	52	90	65	190	115	345	127	150	228	14
4"	52	57	145	312	52	90	65	190	115	380	148	150	228	19
5"	56	61	160	342	52	90	65	215	165	410	178	150	228	19
6"	56	62	175	372	52	90	65	215	165	440	205	150	228	19
8"	60	65	200	442	72	125	85	280	205	530	260	200	303	28
10"	68	72	250	530	72	125	85	280	295	618	318	200	303	32
12"	78	85	275	585	72	125	85	280	295	673	371	200	303	32

*IL = INSTALLED LENGTH (+/- 2 mm for 2"-10" and +/- 3 mm for 12").
*BL = BUILDING LENGTH (+/- 2 mm for 2"-10" and +/- 3 mm for 12").

Technical data			
Size	Closed max. torque at 300 psi (N.m)*	Weight kg	Turns to open
2"	43	7,50	10
2,5"	69	8,00	10
3"	89	8,50	10
4"	117	11,00	10
5"	138	14,50	10
6"	178	15,00	12,5
8"	303	29,50	12,5
10"	482	/	12,5
12"	750	/	12,5

*Torque values shown are without gearbox.

Gearbox connection - Dimensions

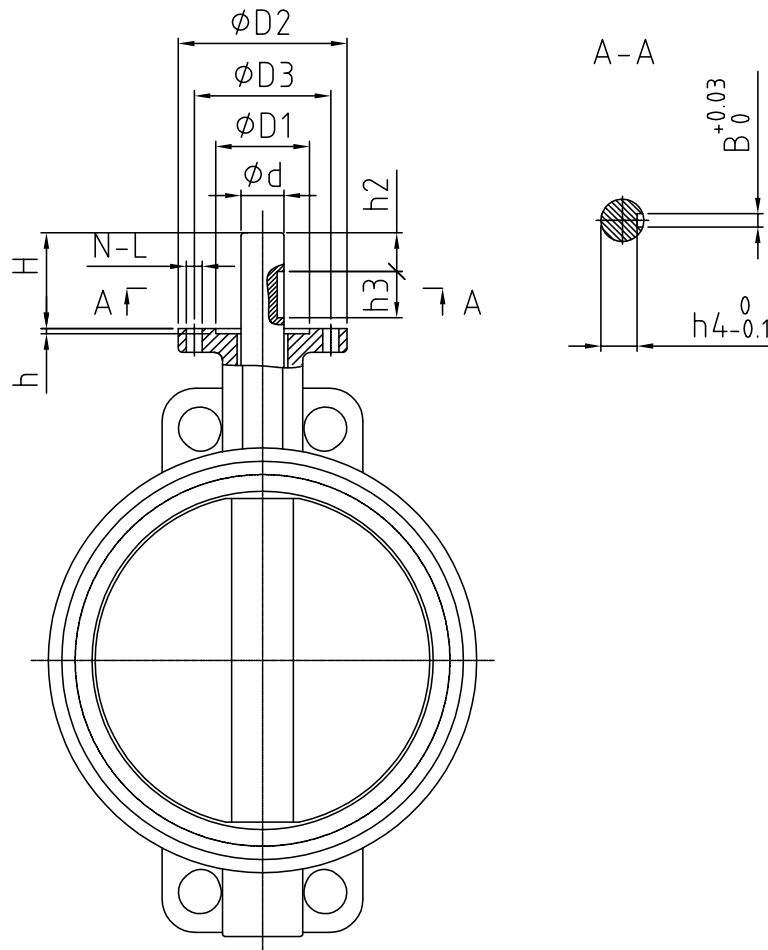

Dimensions (mm)											
Size	D2	D1	D3	h	d	H	N - L	h2	h3	B	h4
2"	90	40	70	2	14	52	4 - $\phi 10$	23	25	5	11
2,5"	90	40	70	2	14	52	4 - $\phi 10$	23	25	5	11
3"	90	40	70	2	14	52	4 - $\phi 10$	23	25	5	11
4"	90	40	70	2	19	52	4 - $\phi 10$	23	25	6	15,5
5"	90	40	70	3	19	52	4 - $\phi 10$	21	25	6	15,5
6"	90	40	70	3	19	52	4 - $\phi 10$	22	25	6	15,5
8"	125	50	102	3	28	72	4 - $\phi 12$	35	30	8	24
10"	125	70	102	4	32	72	4 - $\phi 12$	29	35	10	27
12"	125	70	102	4	32	72	4 - $\phi 12$	31,5	35	10	27

Marking

Body:

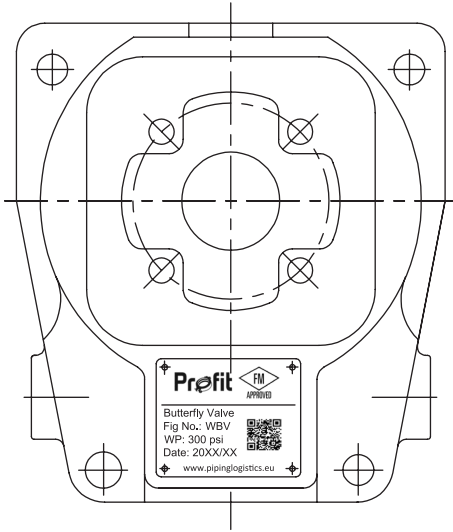

Marking plate:

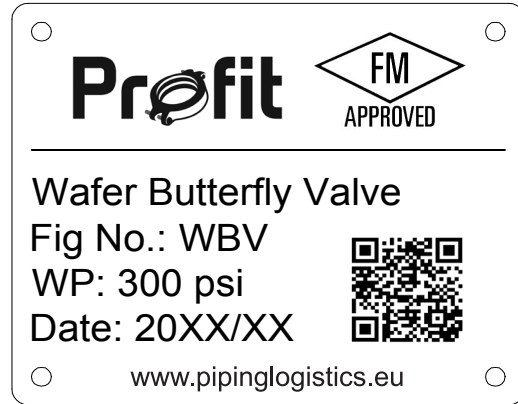

Micro-switches wiring diagrams

Switch Type:

VS10N021C2

Rating:

10 A@125V AC / 10 A@250V AC
0,4A@125V DC / 0,2A@250V DC

Electrical wires:

Seven multi-unit copper wires;

- SWITCH 1: one yellow wire, one red wire, one white wire;
- SWITCH 2: one orange wire, one black wire, one blue wire;
- one green wire (ground).

Diameter of section:

1,5mm² for green wire, the others are 2,5mm². Extend 200mm beyond the gearbox.

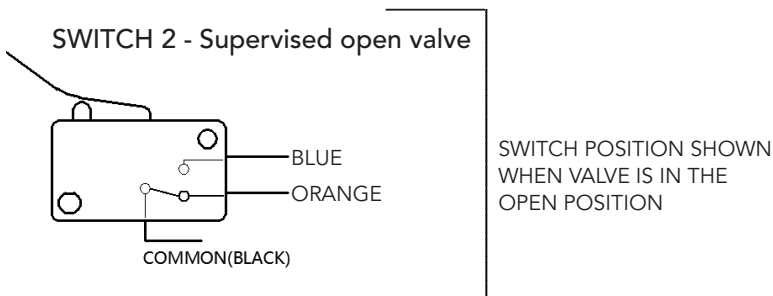
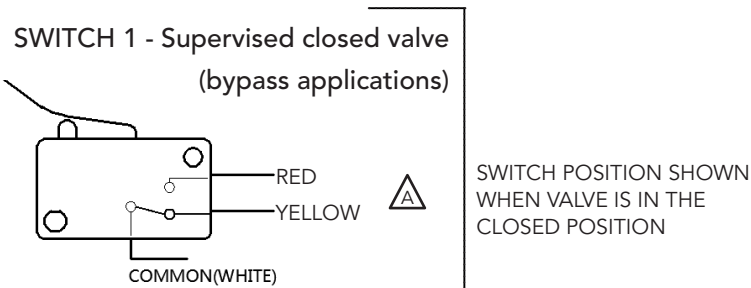

Performances

1. Frictional resistance (based on VdS-report).

Equivalent length

Size		Equivalent length	On steel pipe
DN 50	2"	3,4 m	60,3 x 2,3 m
DN 65	2,5"	2,9 m	76,1 x 2,6 m
DN 80	3"	2,4 m	88,9 x 2,6 m
DN 100	4"	3,9 m	114,3 x 3,2 m
DN 125	5"	4,2 m	139,7 x 3,6 m
DN 150	6"	5,5 m	168,3 x 4,0 m
DN 200	8"	5,8 m	219,1 x 5,6 m

Cv/Kv-values:

Size		Cv	Kv
DN 50	2"	99	86
DN 65	2,5"	188	163
DN 80	3"	341	295
DN 100	4"	500	433
DN 125	5"	763	660
DN 150	6"	1616	1398
DN 200	8"	3237	2800

Pressure drop chart:

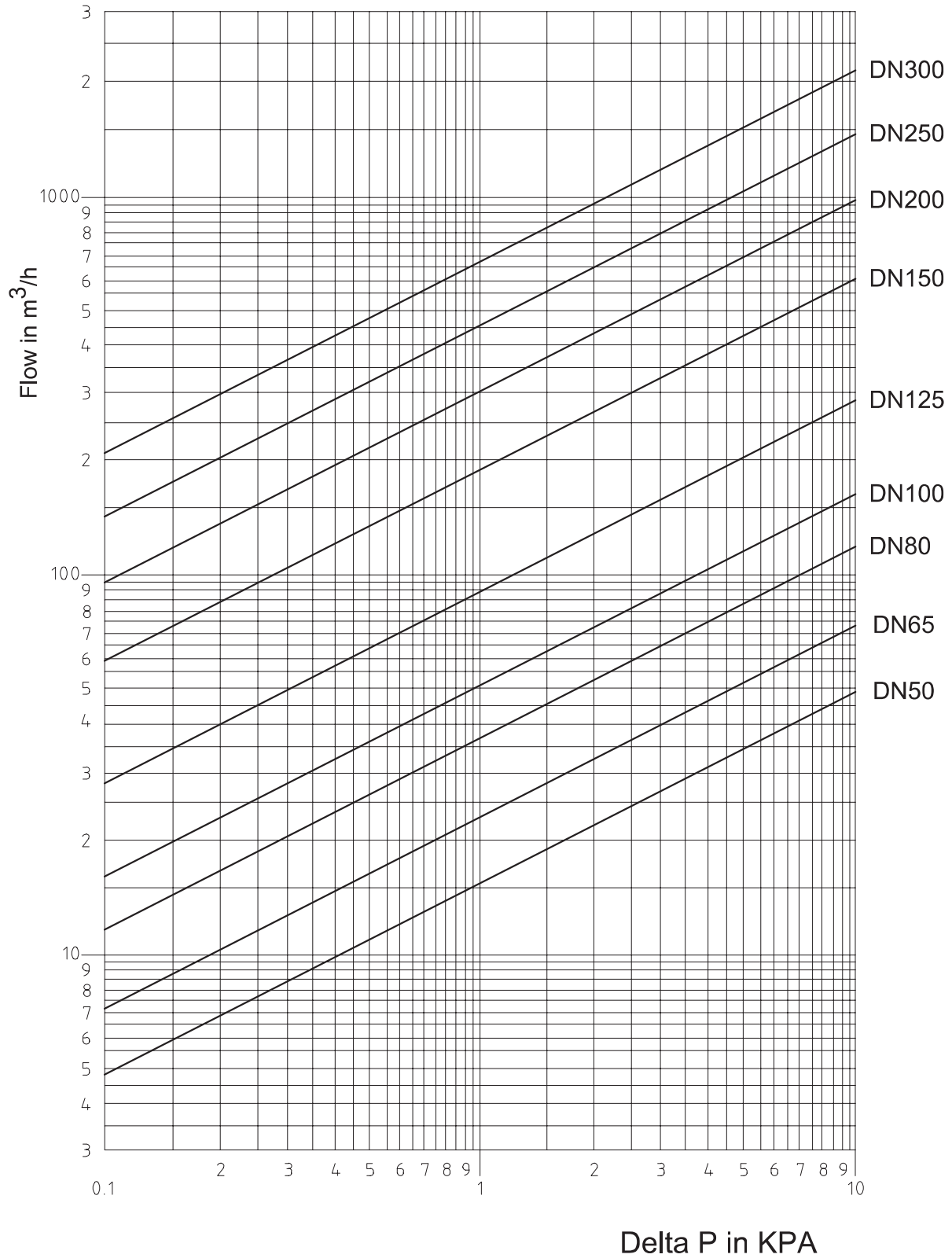

Certifications

Size	FM
DN 50	2" Up to 20,7 bar / 300 psi
DN 65	2,5" Up to 20,7 bar / 300 psi
DN 80	3" Up to 20,7 bar / 300 psi
DN 100	4" Up to 20,7 bar / 300 psi
DN 125	5" Up to 20,7 bar / 300 psi
DN 150	6" Up to 20,7 bar / 300 psi
DN 200	8" Up to 20,7 bar / 300 psi
DN 250	10" Up to 20,7 bar / 300 psi
DN 300	12" Up to 20,7 bar / 300 psi



Storage and handling

- Upon receipt, carefully check the valve-body and gearbox on any damage during shipment.
- Valves should be lifted using the centring lugs, never use the waterway-passage through the valve.
- WBV valves should be stored indoor, protect the rubber seating from direct sunlight.
Storage is recommended with the disc slightly turned open.
- When stored outside, protect the valve from weather and accumulation of water, dirt, or debris.



Installation

- Inspection before installation. Checklist:
 1. Check pressure rating of the valve is compatible with the service conditions.
 2. WBV valves may be installed with any schedule or pressure class of pipe that is listed according to the applicable standard.
 3. Check the flanges adjacent to the valve. WBV valves can be installed between flanges of the following standards:
 - * EN 1092/PN10
 - * EN 1092/PN16
 - * ASTM B16.5 Class 125
 - * ASTM B16.5 Class 150

Please check the internal diameter (ID) of the piping flanges, the minimum values are given in the table below:

Size	IL	ID
2"	43	52
2,5"	46	65
3"	46	77
4"	51,5	97
5"	56	121
6"	56,5	149
8"	60	200
10"	68	250
12"	78	300



1. To prolong the valve-life, we recommend to install the valve not closer than 5-6 x DN when installed downstream near fittings (bends and tees). Pipework must be supported near the valve and the adjacent pipes must be well aligned so that no extra stress will be exerted on the valve-body.
 2. For replacements: all pipes need to be depressurized and purged before starting the installation.
 3. Check that valve-body is clean inside and that the two rubber sealing-facings are clean and free of dust/debris.
 4. Open and close the valve to ensure that it operates properly.
 5. Turn then the valve in almost closed position.
 6. Check that the available length between the flanges matches the total building length of the valve.
 7. Personnel for the installation must be qualified for the task.
 8. Please note that these valves are mainly designed for open/close function. When using the valve for throttling services the disc should not be positioned less than 30° open, to avoid cavitation and related vibrations and noise.
- Installation of the valve:
 1. The valves are bi-directional. They can be installed both horizontally or vertically.
 2. The use of extra gaskets on the rubber facings is NOT allowed, the valves are self-sealing when installed between the listed flange-types.
 3. Separate the 2 pipe-flanges and position de valve between the flanges, use the 4 lug-holes to ensure proper centering.
 4. Relax the flanges and install all bolts and nuts handtight.
 5. Check the free movement of the disc by fully opening the valve.
 6. Tighten now all bolts using the recommended torque values of table below.
 7. For correct tightening please apply cross-over sequence.
 8. Finally double check once more the free movement of the disc by fully opening and closing of the the valve.
 9. Bolt Torque table (PN16):

Size	Recommended minimum Bolt torque - Nm
2" - 5"	110
6" - 8"	210
10" - 12"	370

Bolt dimensions for PN-16 bolt connections (EN 1092-PN16)

DN	Number of bolts	Bolt-nut size mm	Bolt length mm
50	4	M 16	110
65	8 (or 4)	M 16	110
80	8	M 16	110
100	8	M 16	120
125	8	M 16	130
150	8	M 20	130
200	12	M 20	150
250	12	M 24	160
300	16	M 24	180

BOLT TORQUE SEQUENCE

(Bolt N°1 is the bolt closest to biggest gap between the 2 flanges)

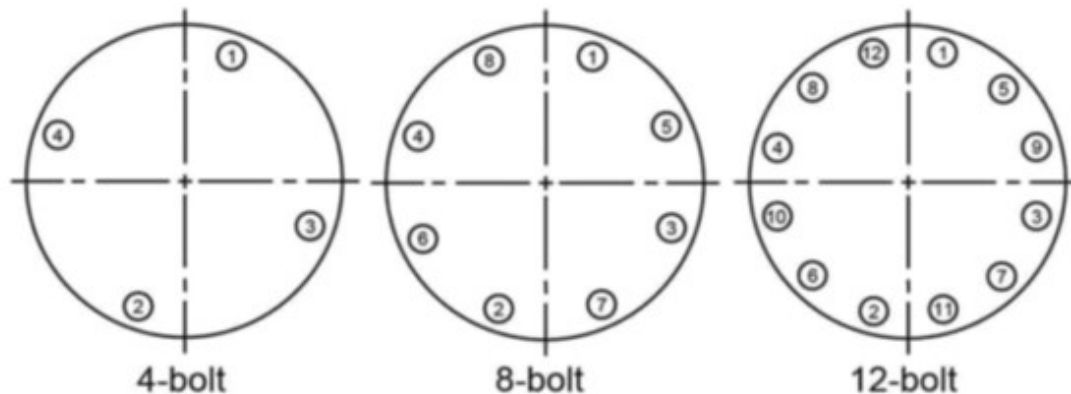

Our advice =

- STEP 1 = 30%
- STEP 2 = 60%
- STEP 3 = 100%

BOLT TORQUE = depends on gasket type used and bolt material grade.



Maintenance

- WBV valves are basically installed maintenance-free. We advise to verify at least annually (or scheduled in agreement with the local authority or competent maintenance company) that the valve operates properly. Also check for any leaks between flanges or between gearbox and body.
- When the valve is blocked, please do not use excessive force or torque on the handwheel but take the valve out to check the cause.
- When a problem of any kind occurs, please contact technical dpt. of Piping Logistics.
- The owner of the system is responsible for testing and inspection of the sprinkler system, in accordance with the applicable standard. We recommend that this testing is done by a qualified inspection service company.

GENERAL INFO

- Installers should be trained or experienced to install and understand the product.
- Read and understand all technical datasheets and installation instructions before attempting to install, remove or adjust any Profit piping products.
- Depressurise and drain the sprinkler installation system before attempting to install, remove or adjust any Profit Piping products.
- Never work on piping-systems that are pressurised and / or filled with water.
- Use the necessary Personal Protection Equipment (PPE) to avoid personal injury (helmet, safety shoes and goggles, Profit gloves).



Failure to follow these instructions could result in death or serious injury and property damage.

We advise to always store our products in closed and dry environments, the products do not need any specific maintenance once installed on an aboveground sprinkler installation.

REVISION TABLE

Date	△	Notes
22/03/2024	A	Page 4 - SWITCH 1: the colours 'yellow' and 'red' have been reversed.
25/06/2024	B	Page 7 - Addition of the internal diameter of the piping flanges for sizes 10" and 12".
09/07/2024	C	Page 1 - The approvals have been added.