

Size range: 2" - 12"

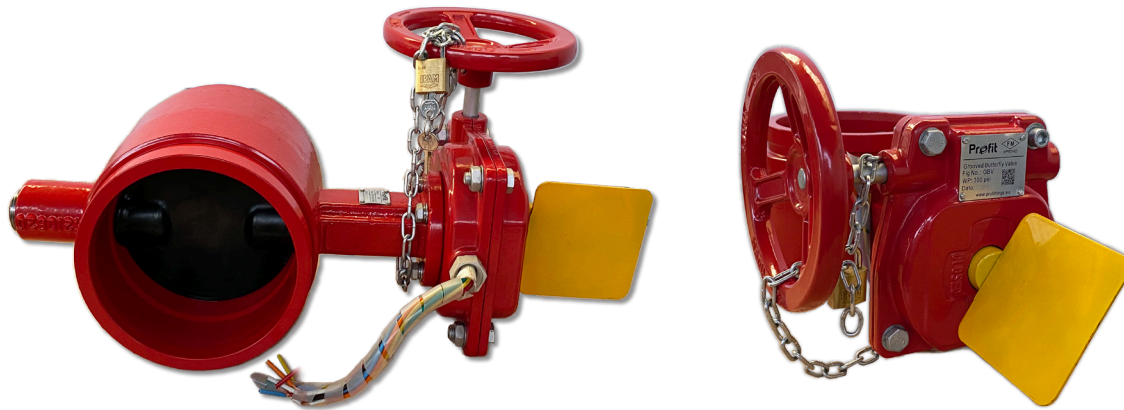

Profit butterfly valves type GBV are indicating valves. They have a grooved in-and outlet and for installation the use of two Profit rigid couplings is recommended. The valves are designed to be used in fire protection sprinkler systems and HVAC systems.

Characteristics

- Indoor use.
- Manually operated with external gearbox with open / close directions on handwheel.
- Yellow open / close position indicator.
- Two built-in micro-switches, pre-wired.
- One of the switches is activated before the handwheel has rotated 2 full turns from the fully OPEN position.
- The second switch is activated before the handwheel has rotated 2 full turns from the full CLOSED position (bypass application).
- E/E dimension comply with MSS SP-67.
- Grooved ends acc. AWWA C606 standard.
- Installation by use of two rigid mechanical couplings.
- Anti-corrosion protection: high grade polyester powder coating, RAL 3000, meets or exceed AWWA C550 standards.
- Recommended max. flow velocity = 5m/sec.
- In compliance with EN 593.

Working temperature

+1°C to +80°C

Working pressure

20,7 barg / 300 psi

Approvals

- FM approved to FM standard 1112
- CNPP certified

Material specifications

Handweel with chain and lock.

Component	Specification	European standard	ASTM standard
Body	Ductile cast iron	EN-GJS-450-10	A 536 gr 65-45-12
Gearbox housing	Grey cast iron	EN-GJL-250	A 126 Class B
Disc	Ductile cast iron	EN-GJS-450-10	A 536 gr 65-45-12
Seat	EPDM rubber	/	D2000
Fasteners	Carbon steel	Gr 4.6	A 307 Gr B
Bushing	Brass	2.038	B 124 C 37700
Shaft	Stainless steel	1.4057	A 276 grade 431
Micro-switch (2x)	VS10 N0 21C2	/	/

Dimensions

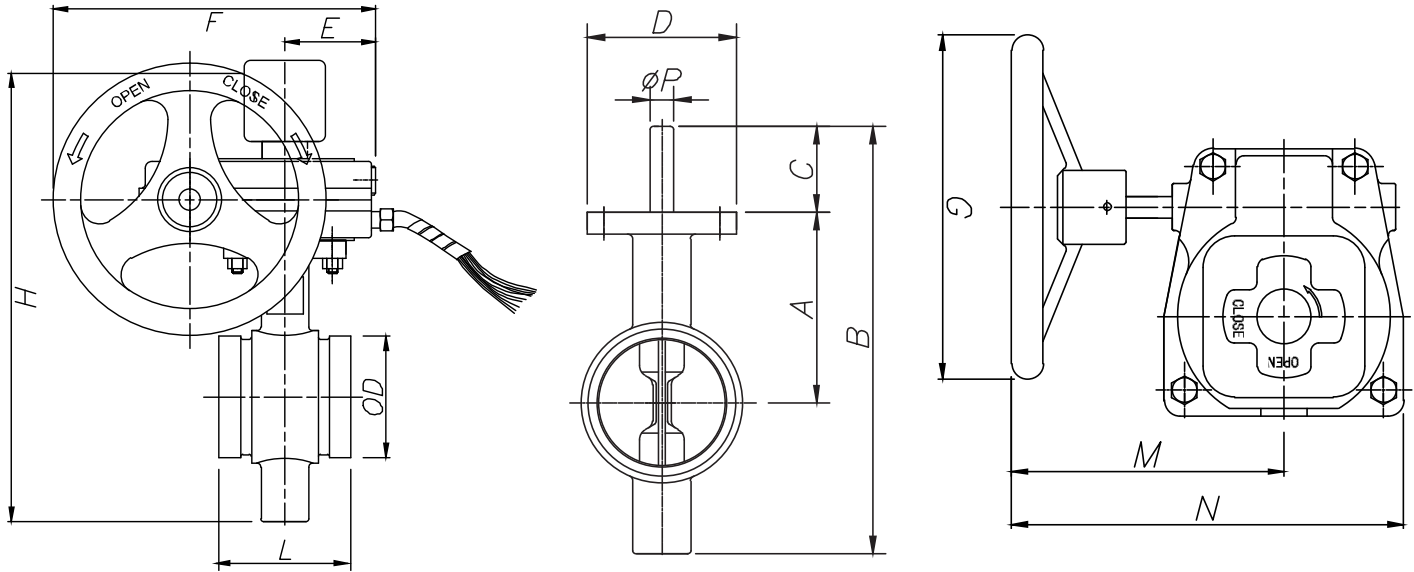

Dimensions (mm)													
Size	OD	L	A	B	C	D	E	F	G	H	M	N	P
2"	60,3	84	99	228	52	90	65	190	115	296	150	228	11
2,5"	73,0 / 76,1	97	112	249	52	90	65	190	115	317	150	228	11
3"	88,9	97	115	257	52	90	65	190	115	325	150	228	14
4"	114,3	116	145	305	52	90	65	190	115	373	150	228	19
5"	139,7 / 141,3	148	139	311	52	90	65	215	165	379	157	235	19
6"	165,1 / 168,3	148	185	382	52	90	65	215	165	450	157	235	19
8"	219,1	133	200	452	72	125	85	280	205	540	205	310	28
10"	273,1	159	250	552	72	125	85	280	295	640	230	333	32
12"	323,9	165	275	607	72	125	85	280	295	695	230	333	32

Technical data			
Size	Closed Max. Torque at 300psi (N.m)*	Weight kg	Turns to open
2"	38	7,50	10
2,5"	64	8,00	10
3"	78	8,50	10
4"	112	11,00	10
5"	125	13,50	10
6"	165	18,00	12,5
8"	293	28,50	12,5
10"	468	/	12,5
12"	732	/	12,5

*Torque values shown are without gearbox.

Gearbox connection - Dimensions

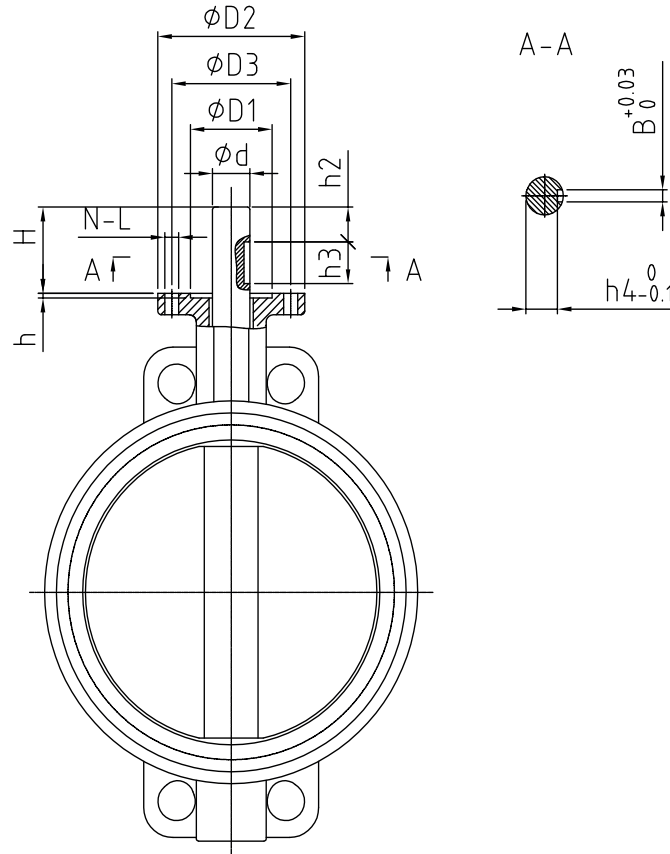

Dimensions (mm)											
Size	D2	D1	D3	h	d	H	N - L	h2	h3	B	h4
2"	90	/	70	/	11	52	4 - $\phi 10$	22	25	4	8,5
2,5"	90	/	70	/	11	52	4 - $\phi 10$	20	25	4	8,5
3"	90	/	70	/	14	52	4 - $\phi 10$	18	25	5	11
4"	90	/	70	/	19	52	4 - $\phi 10$	22,5	25	6	15,5
5"	90	/	70	/	19	52	4 - $\phi 10$	20	25	6	15,5
6"	90	55	70	3	19	52	4 - $\phi 10$	25	25	6	15,5
8"	125	70	102	2,5	28	72	4 - $\phi 12$	28,5	30	8	24
10"	125	70	102	2,5	32	72	4 - $\phi 12$	25	35	10	27
12"	125	70	102	2,5	32	72	4 - $\phi 12$	22,5	35	10	27

Marking

Body:

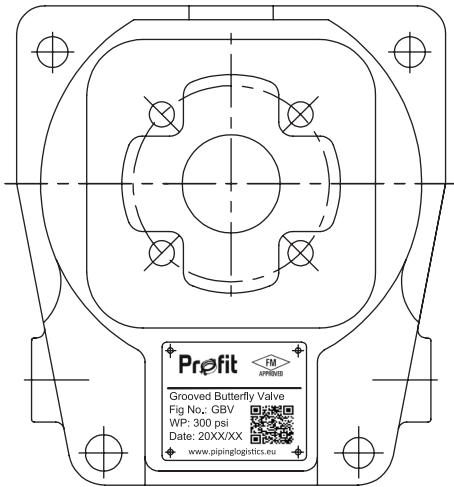

Marking plate:

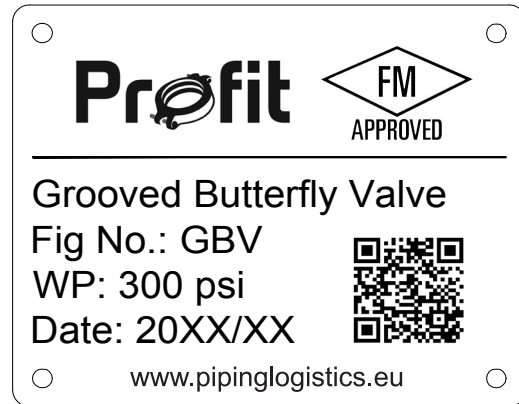

Micro-switches wiring diagrams

Switch Type:

VS10N021C2

Rating:

10 A@125V AC / 10 A@250V AC
0,4A@125V DC / 0,2A@250V DC

Electrical wires:

Seven multi-unit copper wires;

- SWITCH 1: one yellow wire, one red wire, one white wire;
- SWITCH 2: one orange wire, one black wire, one blue wire;
- one green wire (ground).

Diameter of section:

1,5mm² for green wire, the others are 2,5mm². Extend 200mm beyond the gearbox.

SWITCH 1 - Supervised closed valve
(bypass applications)

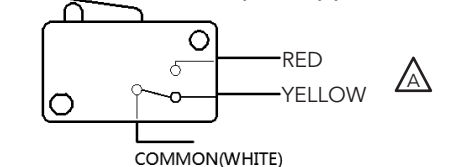

SWITCH POSITION SHOWN
WHEN VALVE IS IN THE
CLOSED POSITION

SWITCH 2 - Supervised open valve

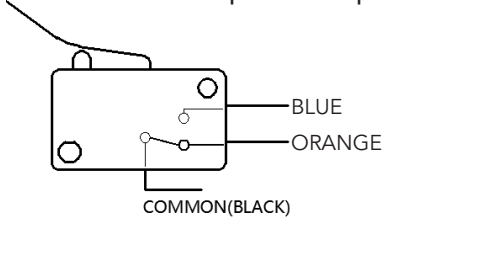

SWITCH POSITION SHOWN
WHEN VALVE IS IN THE
OPEN POSITION

Performances

1. Frictional resistance (based on VdS-report).

Equivalent length

Size	Equivalent length	On steel pipe
DN 50	2"	1,8 m
DN 65	2,5"	2,1 m
DN 80	3"	2,4 m
DN 100	4"	3,9 m
DN 125	5"	4,2 m
DN 150	6"	5,3 m
DN 200	8"	5,6 m

Cv/Kv-values:

Size	Cv	Kv
DN 50	130	113
DN 65	209	181
DN 80	393	340
DN 100	548	474
DN 125	715	618
DN 150	1394	1206
DN 200	2966	2566

Pressure drop chart:

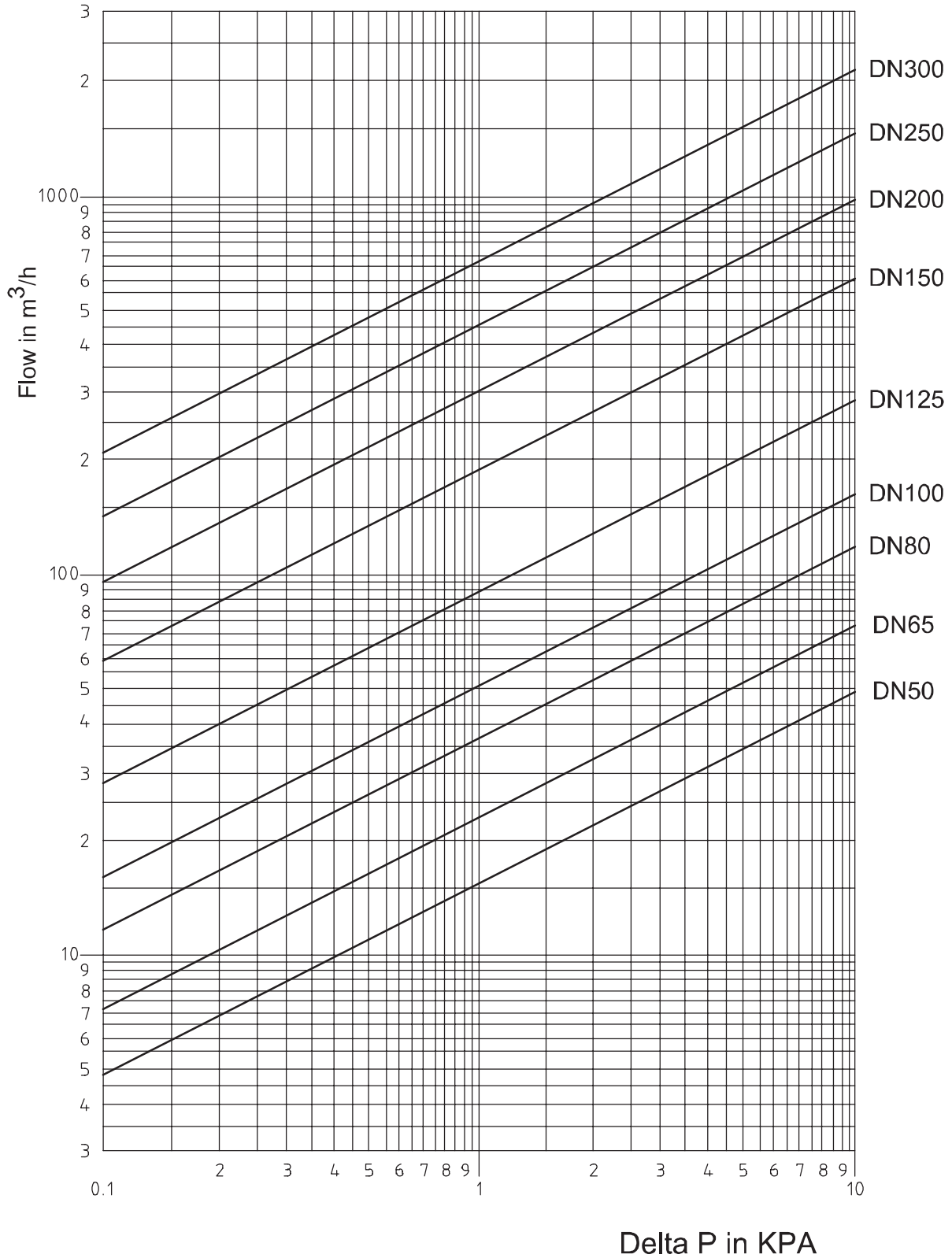

Certifications

Size	FM
DN 50	2" Up to 20,7 bar / 300 psi
DN 65	2,5" Up to 20,7 bar / 300 psi
DN 80	3" Up to 20,7 bar / 300 psi
DN 100	4" Up to 20,7 bar / 300 psi
DN 125	5" Up to 20,7 bar / 300 psi
DN 150	6" Up to 20,7 bar / 300 psi
DN 200	8" Up to 20,7 bar / 300 psi
DN 250	10" Up to 20,7 bar / 300 psi
DN 300	12" Up to 20,7 bar / 300 psi



Storage and handling

- Upon receipt, carefully check the valve-body and gearbox on any damage during shipment.
- Valves should not be lifted by using the waterway-passage through the valve.
- GBV valves must be stored indoor, protected the rubber seating from direct sunlight. Storage is recommended with the disc slightly turned open.
- When stored outside, protect the valve from weather conditions and avoid accumulation of water, dirt, or debris.



Installation

- Inspection before installation. Checklist:
 1. Check pressure rating of the valve and the installation couplings are compatible with service conditions.
 2. GBV valves may be installed with any schedule or pressure class of pipe that is listed or approved with the applied coupling.
 3. Open and close the valve to ensure that it operates properly.
 4. Check that valve-body is clean inside and that the grooves are clean and free of dust/debris.
Turn the valve in almost closed position.
 5. Pipework must be supported near the valve; pipes must be well aligned so that no extra stress will be exerted on the valve-body during installation.
 6. To prolong the valve-life, we recommend to install the valve not closer than 5-6 x DN when installed downstream near a fitting (bends and tees).

7. Check the groove dimension (with groove-gauge) in the adjacent pipework.

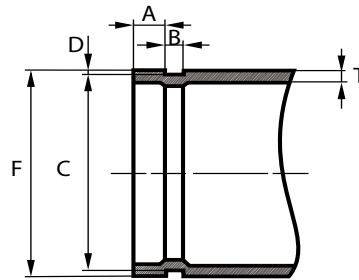

Nominal pipe size		Outside diameter			Gasket seat A	Groove width B	Groove diameter C		Groove depth* D	Maximum outspread F
NPS (DN)	Size mm	+ mm	- mm	Tolerance +0,4 / -0,8 mm	Tolerance +0,8 / -0,4 mm	Size mm	Tolerance mm	mm	mm	
1	25	33,7	0,41	0,68	15,9	7,1	30,2	+0/-0,3	1,6	34,5
1¼	32	42,4	0,50	0,60	15,9	7,1	39,0	+0/-0,4	1,6	43,3
1½	40	48,3	0,44	0,52	15,9	7,1	45,1	+0/-0,4	1,6	49,4
2	50	60,3	0,61	0,61	15,9	8,7	57,2	+0/-0,4	1,6	62,2
2½	65	76,1	0,76	0,76	15,9	8,7	72,3	+0/-0,4	2,0	77,7
3	80	88,9	0,89	0,79	15,9	8,7	84,9	+0/-0,4	2,0	90,6
4	100	114,3	1,14	0,79	15,9	8,7	110,1	+0/-0,5	2,2	116,2
5	125	139,7	1,40	0,79	15,9	8,7	135,5	+0/-0,5	2,2	141,7
6	150	168,3	1,60	0,79	15,9	8,7	164,0	+0/-0,6	2,2	170,7
8	200	219,1	1,60	0,79	19,1	11,9	214,4	+0/-0,6	2,4	221,5
10	250	273,0	1,60	0,79	19,1	11,9	268,3	+0/-0,7	2,4	275,4
12	300	323,9	1,60	0,79	19,1	11,9	318,3	+0/-0,8	2,8	328,2

*According to standard AWWA C606-06

- Check that the available length between the pipes matches the total length of the valve.
- Please use at least one rigid coupling. When 2 flexible couplings are used, additional support may be required to prevent valve from rotating.
- Replacements: all pipes need to be depressurized and purged before starting the installation.
- Personnel for the installation must be qualified for the task.
- Please note that the GBV valves are mainly designed for open/close functioning. When using the valve for throttling services the disc should not be positioned less than 30° open, to avoid cavitation and related vibrations and noise.

- Installation of the valve
 - The valves are bi-directional and can be installed both horizontally or vertically.
 - Please check the couplings installation instructions; for Profit mechanical couplings the instructions are included in this datasheet (see page 10).



Maintenance

- GBV valves are basically installed maintenance-free. We advise to verify at least annually (or scheduled in agreement with the local authority or competent maintenance company) that the valve operates properly. Also check for any leaks between flanges or between gearbox and body.
- When the valve is blocked, please do not use excessive force or torque on the handwheel but take the valve out to check the cause.
- When a problem of any kind occurs, please contact technical dept. of Piping Logistics.
- The owner of the system is responsible for testing and inspection of the sprinkler system, in accordance with the applicable standard. We recommend that this testing is done by a qualified inspection service company.

COUPLING INSTALLATION INSTRUCTIONS

GENERAL INFO - BEFORE YOU START INSTALLING THE COUPLING

- Installers should be trained or experienced to install and understand the product.
- Read and understand all technical datasheets and installation instructions before attempting to install, remove or adjust any Profit piping products.
- Depressurise and drain the sprinkler installation system before attempting to install, remove or adjust any Profit piping products.
- Never work on piping-systems that are pressurised and /or filled with water.
- Use the necessary Personal Protection Equipment (PPE) to avoid personal injury (helmet, safety shoes, goggles, Profit gloves).
- Use appropriate tooling:
 - Profit groove meter and / or center punch tool
 - Impact-wrench and torque-wrench
 - Correct socket size and depth:



Bolt size	Recommended torque	Socket
	Nm	mm
M8 (1/4)	25-30	13
M10 (3/8)	44-54	15
M12 (1/2)	90-100	18
M14 (9/16)	135-150	21
M16 (5/8)	200-230	24
M20 (3/4)	270-300	30

Failure to follow these instructions could result in death or serious injury and property damage.

We advise to always store our products in closed and dry environments, the products do not need any specific maintenance once installed on an aboveground sprinkler installation.

INSTALLATION INSTRUCTIONS

1 Check the end of the pipe, after the groove, to make sure that there are no bumps, holes or loose coating particles. Remove these first, in order to prevent leaks. Always check the rubber gasket to ensure that it is suitable for the intended service.



2 The outer diameter of the housing and the groove diameter must match the specifications provided by Profit; please review the page with groove specifications.

3 Unscrew the pre-assembled coupling using an impact wrench.



4 Apply PROFIT lubricant onto the sealing lips of the gasket. Also apply lubricant to the interior side of the housings.



5 Slide the gasket over the end of the pipe and make sure that it covers the end completely.

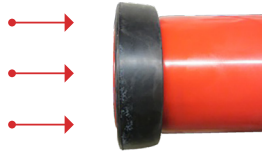

6 Bring the two pipe ends together without misalignments and pull the gasket over the end of the pipe. Make sure that the gasket is in the middle and that it covers both pipe ends.

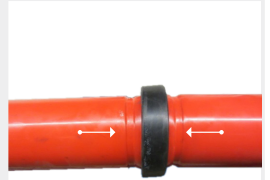

7 Place one coupling shell around the gasket. Once it is placed over the gasket, you shall see that the housing fits in the groove.



8 Stick a bolt through the housing. Make sure that the head of the bolt perfectly fits in the housing.



9 Place the second housing over the bolt and turn the nut finger-tight on the bolt. Then place the second bolt and tighten it finger-tight.



10 Tighten the bolts alternately using an impact wrench with suitable socket wrench until the coupling is completely closed. For proper sealing, bolt-torque standards must be respected (see table). A torque too big cannot improve the sealing property of the coupling; on the contrary it may damage the bolts and/or the housing and can even cause disconnection of the pipes. A torque too small will lead to leakage.



REVISION TABLE

Date	△	Notes
22/03/2024	A	Page 4 - SWITCH 1: the colours 'yellow' and 'red' have been reversed.
09/07/2024	B	Page 1 - The approvals have been added.