

Size range: 3" - 8"



Profit DIAP-DV is a rubber diaphragm that is custom made to fit the Profit dry alarm check valves type DGACV and DFACV. It is an optional spare part intended for maintenance services.

**Working pressure**

Maximum 2,07 MPa / 20,7 bar / 300 psi.

**Working temperature**

Maximum 50°C.

**Material**

Nylon reinforced EPDM rubber.

**Dimensions DIAP-DV-3-4**

For dry valves type DGACV & DFACV 3" & 4".

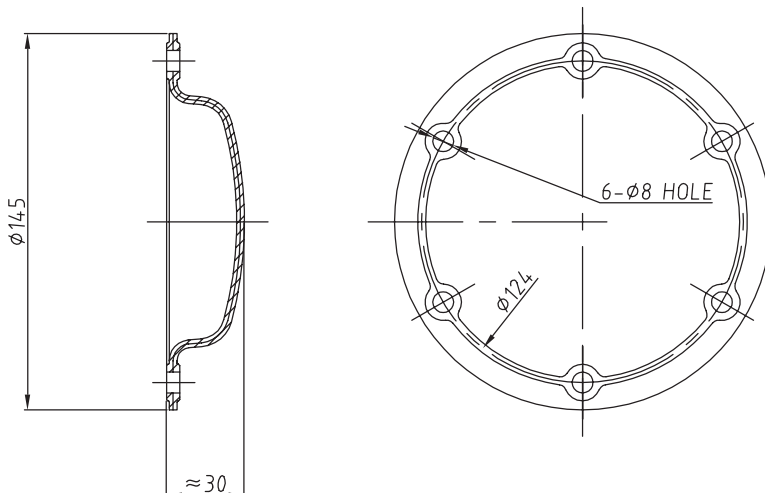

**Dimensions DIAP-DV-6-8**

For dry valves type DGACV & DFACV 6" & 8".

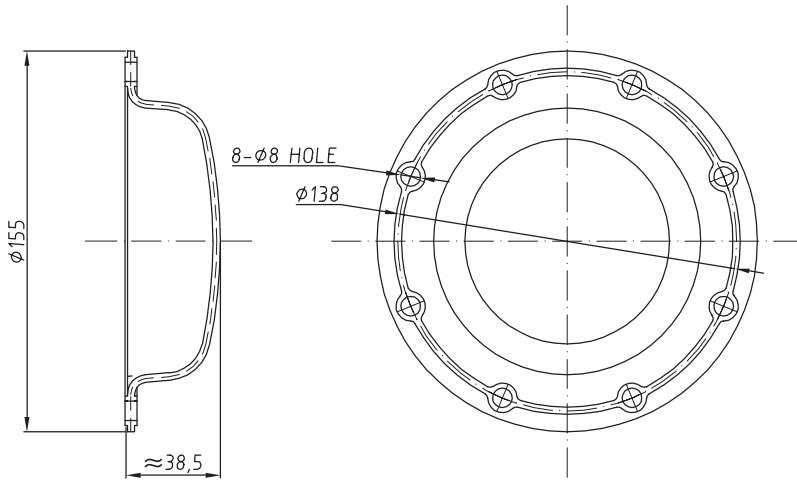

**GENERAL INFO**

- Installers should be trained or experienced to install and understand the product.
- Read and understand all technical datasheets and installation instructions before attempting to install, remove or adjust any Profit piping products.
- Depressurise and drain the sprinkler installation system before attempting to install, remove or adjust any Profit piping products.
- Never work on piping systems that are pressurised and / or filled with water.
- Piping Logistics reserves the right to change specifications, designs and / or standard equipment without notice and without incurring in any obligations.
- Use the necessary Personal Protection Equipment (PPE) to avoid personal injury (helmet, safety shoes and goggles, Profit gloves).



**Failure to follow these instructions could result in death or serious injury and property damage.**

**We advise to always store our products in closed and dry environments, the products do not need any specific maintenance once installed on an aboveground sprinkler installation.**

**REVISION TABLE**

| Date       | △ | Notes            |
|------------|---|------------------|
| 29/07/2024 |   | Initial release. |
|            |   |                  |