

Size range: 3" - 8"

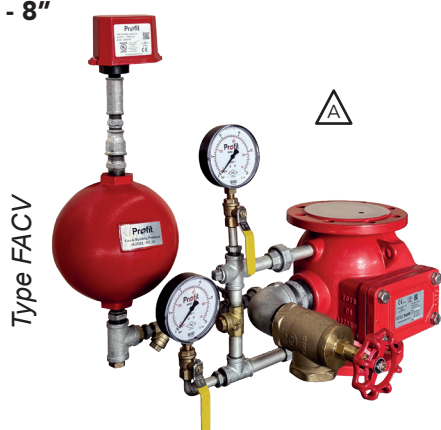

Profit wet alarm check valves type FACV & GACV are swing-type check valves that allow water flow in one direction. They automatically actuate an electric or hydraulic alarm when one or more sprinkler-heads are activated. Type FACV has a fixed flange on the in-and outlet, type GACV has a grooved in-and outlet. The valves are designed to be used in WET fire protection sprinkler systems.

Characteristics

- Indoor use for WET sprinkler systems only.
- Factory pressure tested: 4,14 MPa / 41,4 bar / 600 psi.
- Resilient seating with EPDM-rubber against a bronze ring.
- Gravity operated, swing check design.
- Installation is allowed only in vertical pipes.
- Excellent flow characteristics.
- Valve outer ends:
 - Flanged ends (FACV): according to EN 1092-2/PN16 standard.
 - Grooved ends (GACV): grooves according AWWA.
- Meets the AWWA C 508 standard.
- Including a pre-assembled vertical trimset in accordance with FM / CE regulations.
- The trimset includes a retard chamber and a pressure switch. A water gong motor is available in option. The trim-set features high quality parts and is build-up with union fittings for easy after-service.
- The check valve can stay installed for any needed service works.
- Anti-corrosion protection: high grade polyester powder coating, meets or exceed AWWA C550 standards.
- Check valve can be used outdoors, we do not recommend to use the standard trimset for outdoor application.

Working pressure (water)

- FM: 2,07 MPa / 20,7 bar / 300 psi.
- CE: 1,60 MPa / 16,0 bar / 232 psi.

Working temperature

+1°C to +68°C.

Approvals

- UL 193 listed.
- FM approved to FM standard 1041.
- EAC certified.
- CE certified to EN 12259-2.

How it works

Profit wet alarm check valves prevent reverse flow from sprinkler piping to the water supply.

When a fire occurs and a sprinkler head is operated the valve clapper is lifted and allows water flow from the supply side to the system side. At the same time a small amount of the water will flow into the central chamber of the valve-seat and further to the retard chamber and activates an external alarm. The external alarm can be the pressure switch (standard included) and a water motor gong (optional).

A retard chamber is standard included, this is to prevent false alarms created by pressure surges in the supply line. The inlet and outlet of this retard chamber are designed in such way that the chamber is only filling up when the waterflow is created by an activated sprinkler head. The supply line to the retard chamber has a strainer to prevent orifice blocking.

The standard vertical trim includes also a bypass installed to prevent that the valve would open when a small water flow and / or pressure surges in water supply system occur. This bypass also includes a small check-valve.

Material details & specifications

1. CHECK VALVE WITH FLANGED CONNECTIONS (FACV)

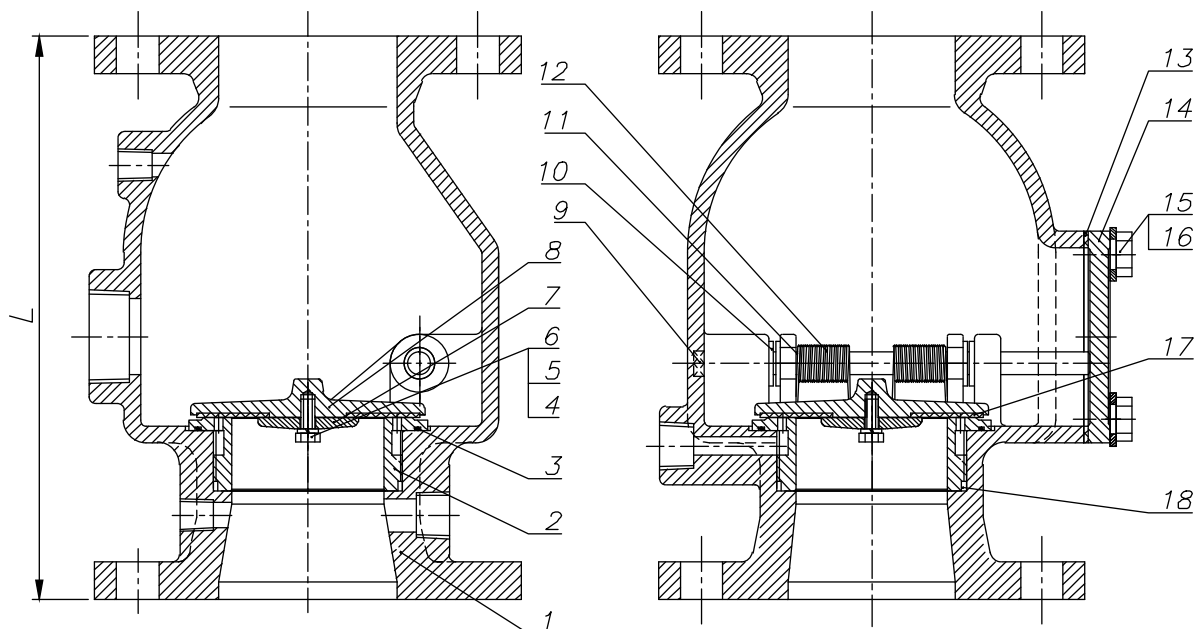

Part N°	Part	Material	European standard	ASTM standard
1	Body Flange detail: EN 1092/PN16	Ductile cast iron	EN-GJS-450-10	A 536 gr 65-45-12
2	Seat	Bronze	CuSn5Pb5Zn	B62 C83600
3	O-ring	EPDM rubber	/	D 2000
4	Bolt	Stainless steel	X5CrNi18-10	A2 -70
5	Disc	Stainless steel	X5CrNi18-10	A2 -70
6	Body seat ring	Stainless steel	X5CrNi18-10	A2 -70
7	Seat retainer	Ductile cast iron	EN-GJS-450-10	A 276 AISI 304
8	Disc	Ductile cast iron	EN-GJS-450-10	A 536 gr 65-45-12
9	Plug	Stainless steel	X5CrNi18-10	A 276 AISI 304
10	Brass	Brass	CuZn36Pb3	B16 C36000
11	Hinge pin	Stainless steel	X5CrNi18-10	A 276 AISI 304
12	Spring	Stainless steel	X5CrNi18-10	A 276 AISI 304
13	Gasket	EPDM rubber	/	D2000
14	Cover	Ductile cast iron	EN-GJS-450-10	A 536 gr 65-45-12
15	Bolt	Stainless steel	X5CrNi18-10	A2 -70
16	Washer	Stainless steel	X5CrNi18-10	A2 -70
17	Disc seat ring	EPDM rubber	/	D2000
18	O-ring	NBR rubber	/	D2000

Dimensions (mm)				
Size	DN80	DN100	DN150	DN200
L	257	270	340	432
Weight (kg)	34	40	63	93

Material details & specifications

2. CHECK VALVE WITH GROOVED CONNECTIONS (GACV)

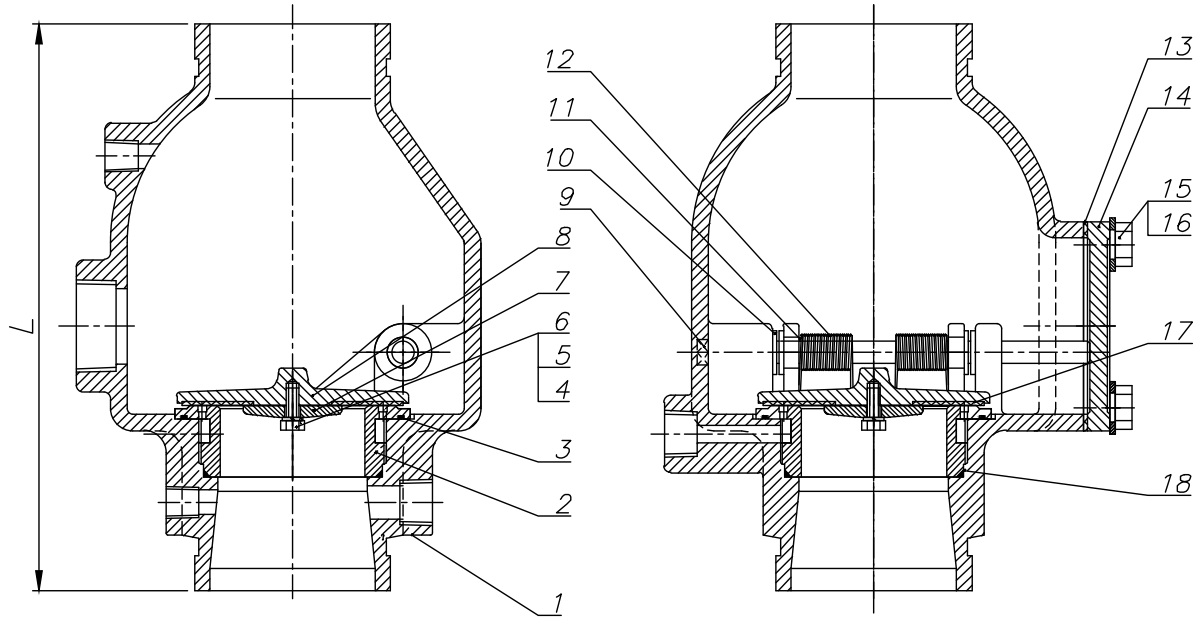

Part N°	Part	Material	European standard	ASTM standard
1	Body Groove detail: AWWA C606-2015	Ductile cast iron	EN-GJS-450-10	A 536 gr 65-45-12
2	Seat	Bronze	CuSn5Pb5Zn	B62 C83600
3	O-ring	EPDM rubber	/	D 2000
4	Bolt	Stainless steel	X5CrNi18-10	A2 -70
5	Disc	Stainless steel	X5CrNi18-10	A2 -70
6	Body seat ring	Stainless steel	X5CrNi18-10	A2 -70
7	Seat retainer	Ductile cast iron	EN-GJS-450-10	A 276 AISI 304
8	Disc	Ductile cast iron	EN-GJS-450-10	A 536 gr 65-45-12
9	Plug	Stainless steel	X5CrNi18-10	A 276 AISI 304
10	Brass	Brass	CuZn36Pb3	B16 C36000
11	Hinge pin	Stainless steel	X5CrNi18-10	A 276 AISI 304
12	Spring	Stainless steel	X5CrNi18-10	A 276 AISI 304
13	Gasket	EPDM rubber	/	D2000
14	Cover	Ductile cast iron	EN-GJS-450-10	A 536 gr 65-45-12
15	Bolt	Stainless steel	X5CrNi18-10	A2 -70
16	Washer	Stainless steel	X5CrNi18-10	A2 -70
17	Disc seat ring	EPDM rubber	/	D2000
18	O-ring	NBR rubber	/	D2000

Dimensions (mm)				
Size	DN80	DN100	DN150	DN200
L	257	270	340	432
Weight (kg)	24	30	50	76

Material details & specifications

3. TRIM-SET FOR FACV & GACV

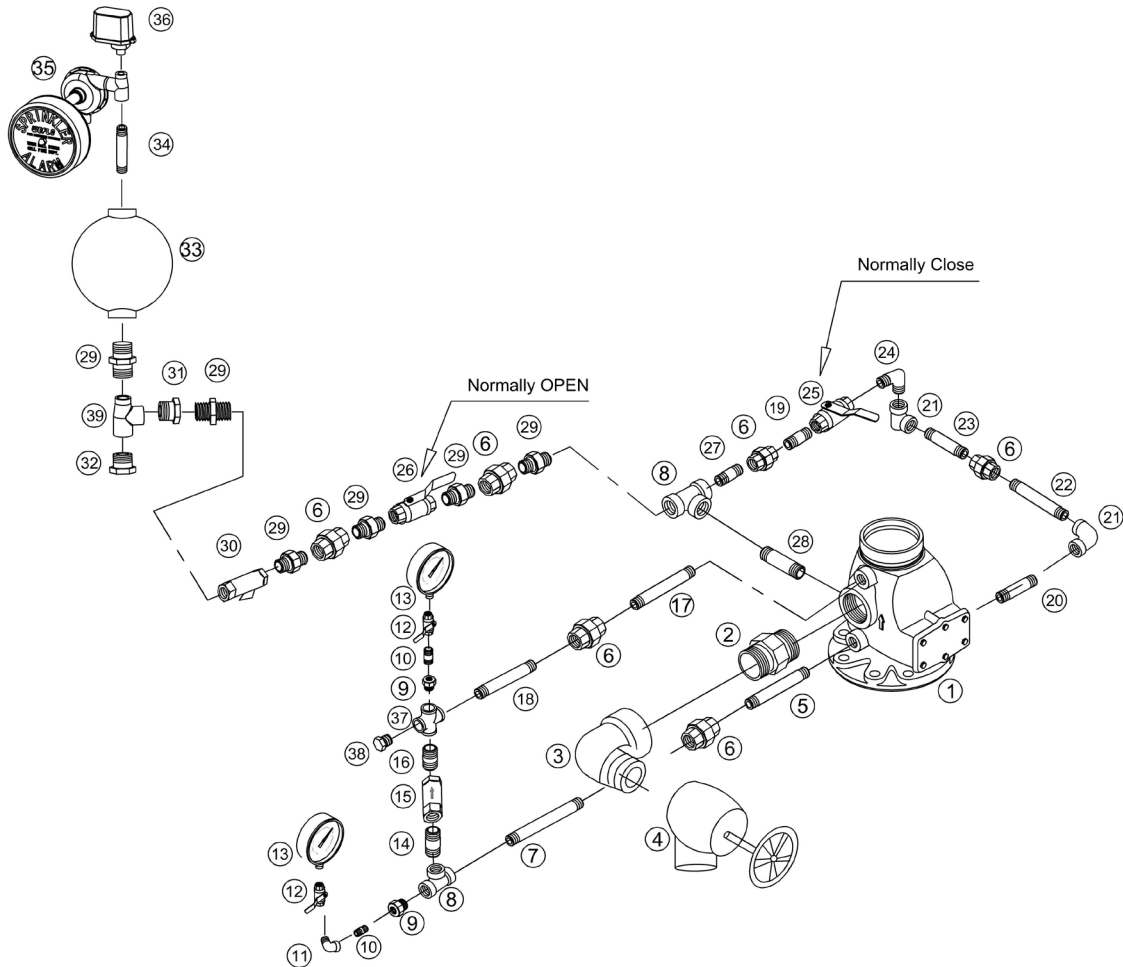

N°	Description	Material
1	Main valve	Assembly
2	NPT pipe fitting	Malleable iron
3	NPT street elbows	Malleable iron
4	Angle valve	Brass
5	½" NPT screwed pipe	Carbon steel
6	½" cone union	Malleable iron
7	½" NPT screwed pipe	Carbon steel
8	½" NPT straight tees	Malleable iron
9	½"x ¼" reducers	Malleable iron
10	¼" NPT screwed pipe	Carbon steel
11	¼" 90° elbows	Malleable iron
12	¼" ball valve (300 psi)	Brass
13	Pressure gauge (0-300 psi)	Assembly
14	½" NPT screwed pipe	Carbon steel
15	½" check valve (300 psi)	Brass
16	½" NPT screwed pipe	Carbon steel
17	½" NPT screwed pipe	Carbon steel
18	½" NPT screwed pipe	Carbon steel
19	½" NPT screwed pipe	Carbon steel
20	½" NPT screwed pipe	Carbon steel

N°	Description	Material
21	½" 90° elbows	Malleable iron
22	½" NPT screwed pipe	Carbon steel
23	½" NPT screwed pipe	Carbon steel
24	½" NPT elbows	Stainless steel, SS304
25	½" ball valve (300 psi)	Brass
26	½" ball valve (PN16, locking function)	Stainless steel, SS304
27	½" NPT screwed pipe	Carbon steel
28	½" NPT screwed pipe	Carbon steel
29	½" NPT pipe fitting	Carbon steel
30	½" Y-Strainer	Brass
31	Restriction orifice	Brass
32	Restriction orifice	Brass
33	Retard chamber	Cast iron
34	¾" NPT screwed pipe	Carbon steel
35	Water motor gong (optional)	Assembly
36	Pressure switch WPS 10-1	Assembly
37	½" NPT union cross	Malleable iron
38	½" NPT plug	Malleable iron
39	¾" x ½" NPT straight tees	Malleable iron

4. TRIM-SET DIMENSIONS GACV

SIZE	A	B	C (Grooved)
DN 80	3"	330	550
DN 100	4"	330	565
DN 150	6"	370	605
DN 200	8"	440	620

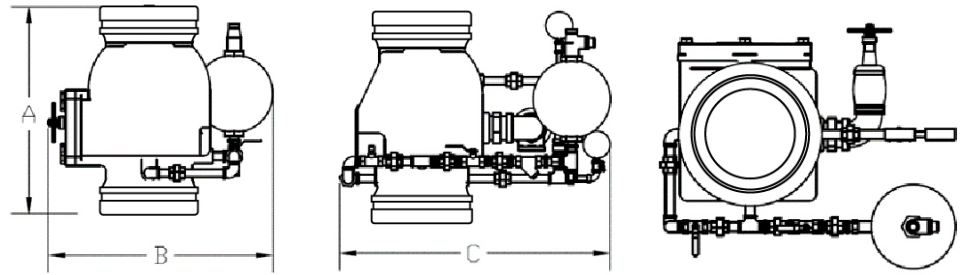

Marking

Body:

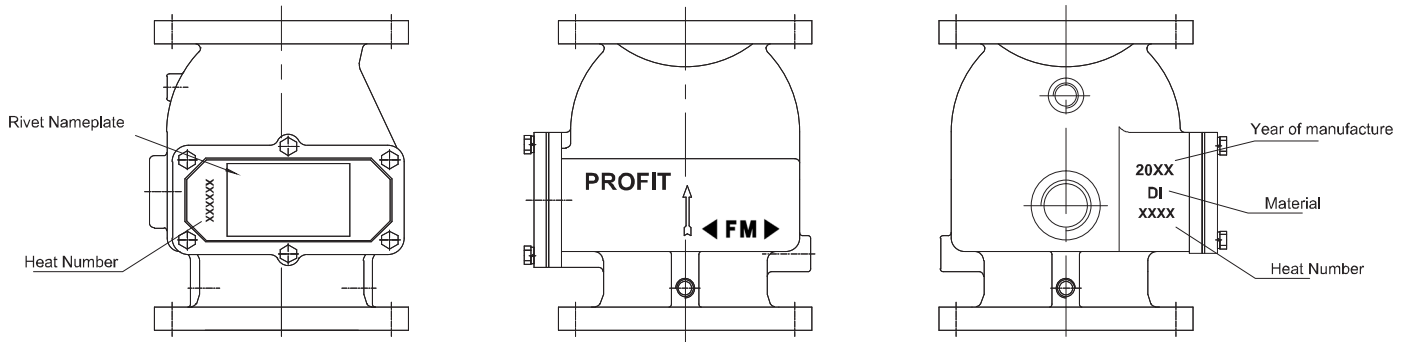

Marking-plate:

GROOVED - GROOVED CONNECTION

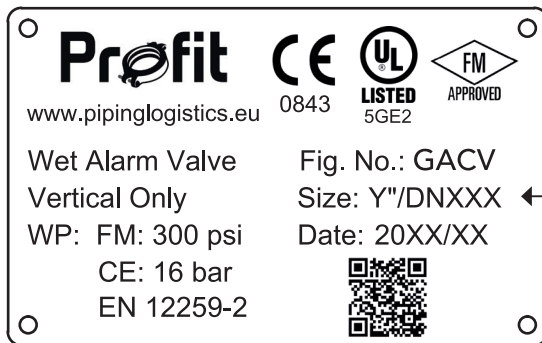

GACV



FLANGED - FLANGED CONNECTION



FACV



Pressure drop charts

[DN80 Test report]

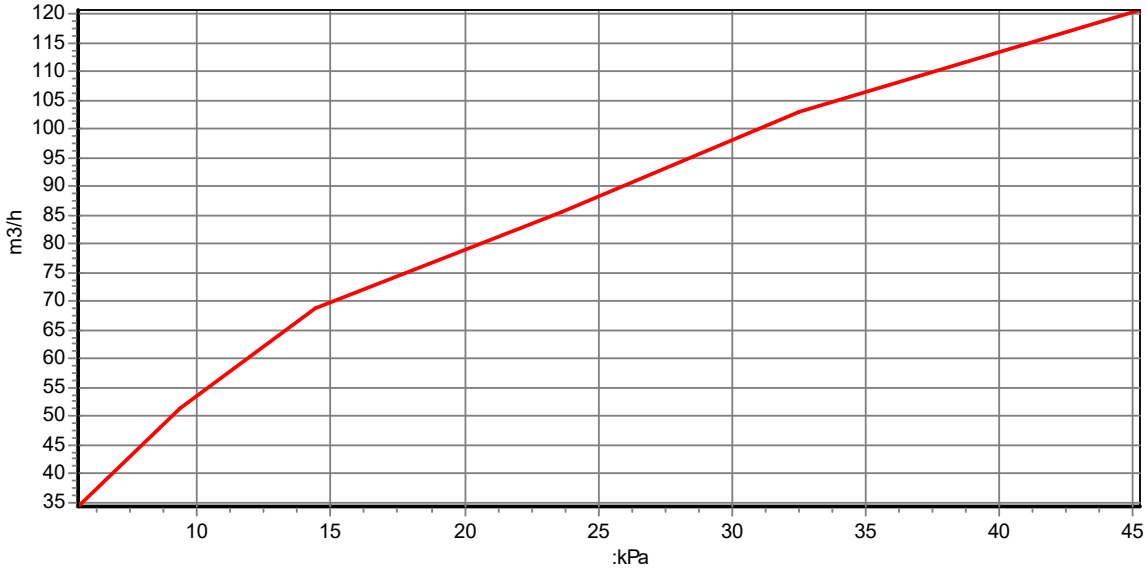

[DN100 Test report]

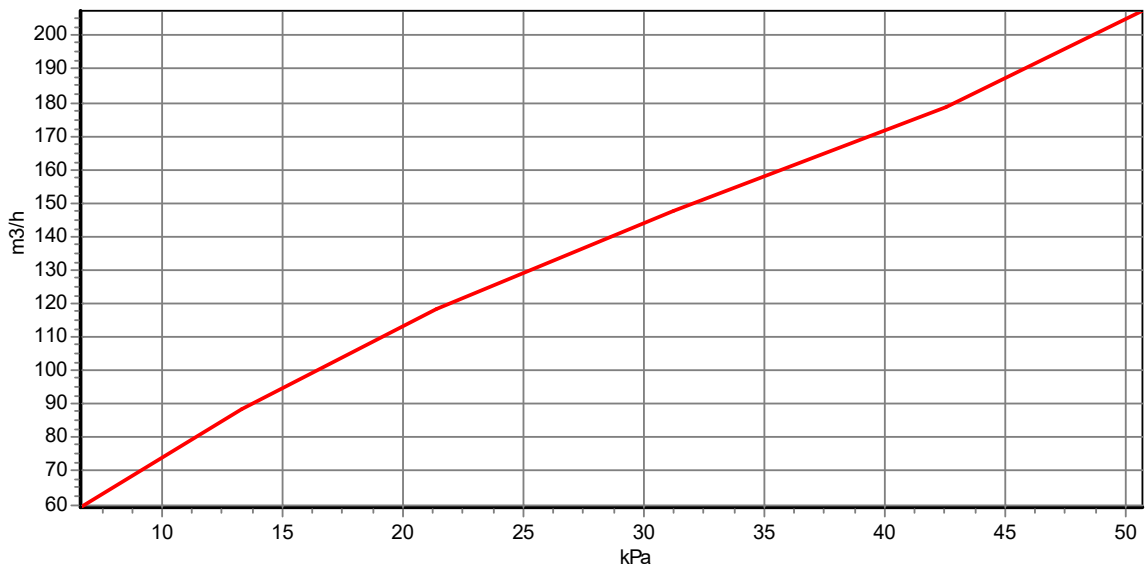

[DN150 Test report]

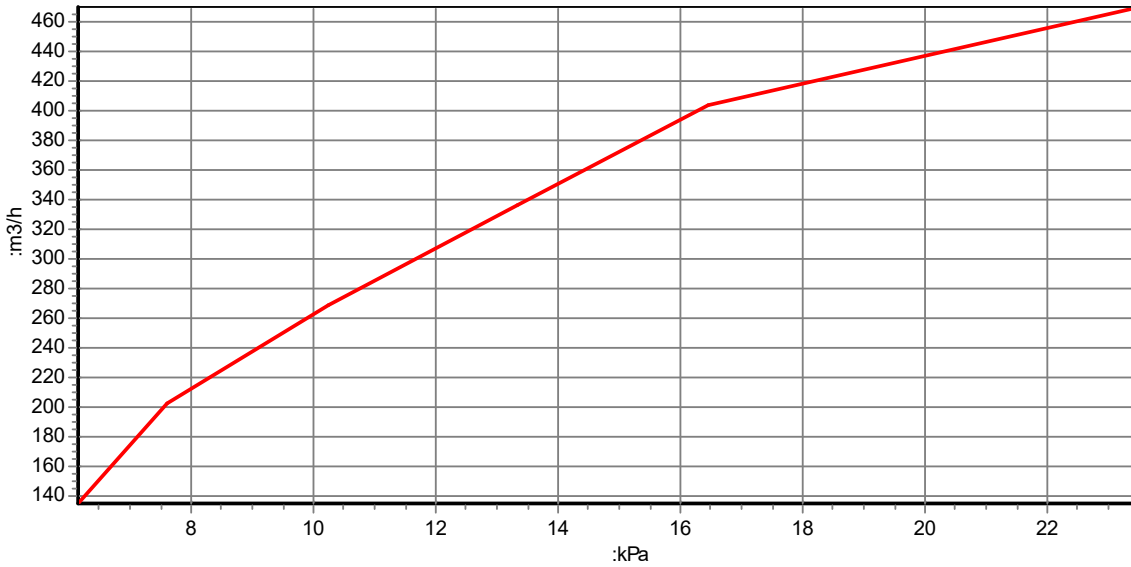

[DN200 Test report]

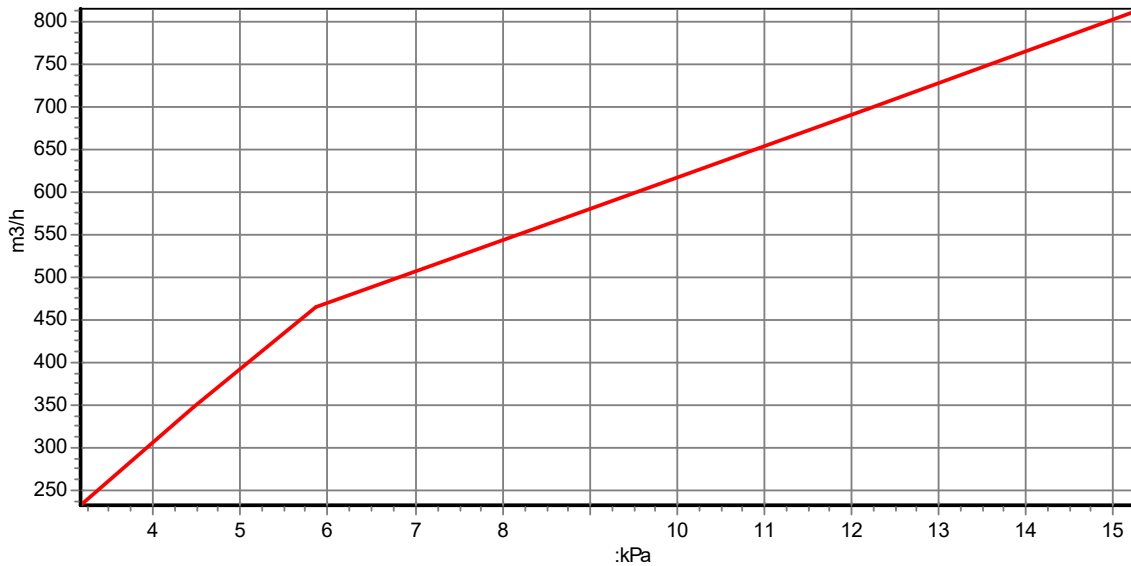

Certifications

Size		FM class 1041	CE EN 12259-2
DN 100	4"	Up to 2,07 MPa / 20,7 bar / 300 psi	Up to 1,60 MPa / 16,0 bar / 232 psi
DN 150	6"	Up to 2,07 MPa / 20,7 bar / 300 psi	Up to 1,60 MPa / 16,0 bar / 232 psi
DN 200	8"	Up to 2,07 MPa / 20,7 bar / 300 psi	Up to 1,60 MPa / 16,0 bar / 232 psi



Storage and handling

- Upon receipt, carefully check complete the valve on any damage during shipment.
- Valves should be unloaded carefully , they should not be lifted by using the waterway-passage through the valve. Do not drop the valve onto the ground.
- FACV & GACV valves must be stored indoor, protect the rubber seating from direct sunlight. When stored outside, protect the valve from weather conditions and avoid accumulation of water, dirt or debris.



Installation

- Inspection before installation. Checklist:
 1. Check if the pressure rating of the valve is compatible with the service conditions. FACV and GACV valves may be installed with any schedule or pressure class of pipe that is listed or approved.
 2. Pipework above and under the valve must be well aligned so that no extra stress will be exerted on the valve-body during installation.
 3. The valves have a flow direction to be respected at installation. There is a clear flow direction arrow on the body. The valves must only be installed in vertical pipes and the flow MUST always be upwards.
 4. No need to lubricate the clapper-hinges or the rubber seating inside.
- FACV:
 1. Check that the standard of the piping flanges on both sides are drilled according the same standard as the valve (EN 1092/PN16). Check that the facings of all flanges are free of dirt and/or mechanical damages.
 2. Check that the available length between the pipe-flanges matches the total length of the valve (+ 2 x gasket-thickness).
 3. Verify that there are two gaskets available to install in between the flanges on both sides. Check if the pressure/temperature rating of the gaskets is suitable.
 4. Check availability of correct bolts & nuts to complete both flange-connections of the valve in- and outlet.
 5. Check that the pipe-flanges are parallel.
 6. Personnel for the installation must be qualified for the task.
- GACV:
 1. Check the groove-dimensions in the pipes above and below the valve. Check that the two rigid couplings to install the valve are available; we advise to use Profit rigid couplings type GKS or GKA.
 2. Check that the available length between the pipes matches the total length of the valve.
 3. Check that valve-body and adjacent pipes are clean inside and that the grooves are clean and free of dust /debris.
 4. For retrofit replacements or repairwork : all pipes need to be depressurized and purged before starting the installation / repair.
 5. Personnel for the installation must be qualified for the task.

- Installation of the FACV-valve:
 1. Separate the 2 pipe-flanges and position the valve with the gaskets between the flanges.
 2. Relax the flanges and install all bolts and nuts handtight.
 3. Tighten now all bolts using the recommended torque values.
 - For correct tightening please apply cross-over sequence.
 - Bolt torque: please consult the gasket datasheet / supplier.
 4. The Profit alarm valves are supplied with fully assembled trim-set. We advise to use this build without any changes to guarantee the correct functioning of the valve.

Bolt dimensions for PN-16 bolt connections (EN 1092-PN16)

DN	Number of bolts	Bolt-nut size mm	Bolt length mm
50	4	M 16	70
65	8 (or 4)	M 16	70
80	8	M 16	70
100	8	M 16	70
125	8	M 16	70
150	8	M 20	90
200	12	M 20	90
250	12	M 24	100
300	16	M 24	100

BOLT TORQUE SEQUENCE

(Bolt N°1 is the bolt closest to biggest gap between the 2 flanges).

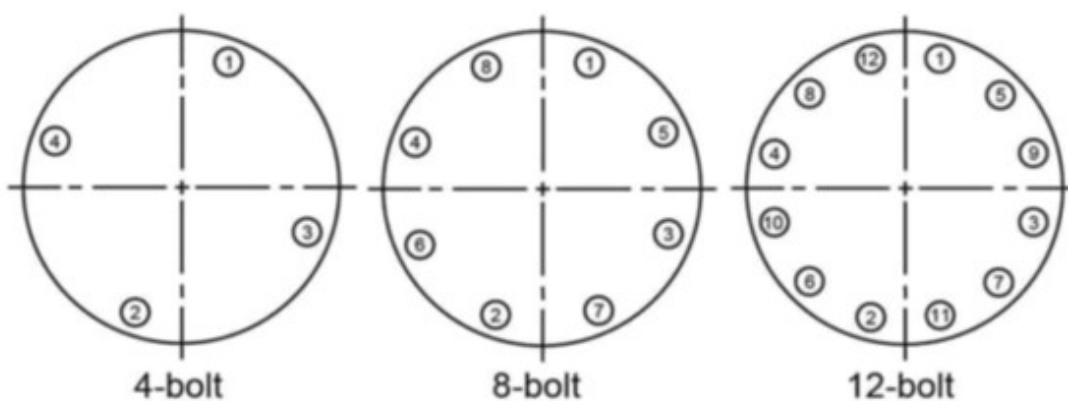

Our advice =

- STEP 1 = 30%
- STEP 2 = 60%
- STEP 3 = 100%

BOLT TORQUE = depends on the applied gasket-type and on the bolt material grade.

- Installation of the GACV-valve:
 1. We refer to our installation instructions of Profit rigid couplings (pg. 13-14).
 2. The Profit alarm valves are supplied with fully assembled trim-set. We advise to use this build without any changes to guarantee the correct functioning of the valve.

- Retard chamber installation:

OPTIONS:

 1. Function with only with pressure switch alarm: add an air inlet valve (aerator).
 2. Function with combined pressure switch and a water motor gong alarm in parallel.

Provide sufficient supporting on the retard chamber or on the drain pipe from the retard chamber.

A possible easy and effective solution for the supporting of the retard chamber is to connect the main drain outlet as shown on below drawings for 'Recommended drain-set'. All indicated parts available from Profit warehouse.

Putting the valve into operation

1. Before start:
 - System is dry or drained. Close the main drain valve (N°4).
 - Two trim-set-gauges indicate pressure zero. Ball valves to both gauges to be open.
 - Open the 'remote system drain valve' (and any auxiliary vents to facilitate air removal from the system).
 - Alarm test ball valve (N°25) is closed.
2. Slowly open the water supply main control valve.
3. Fill the system completely.
4. When there is a steady flow of water and all air released from the system then close the 'remote system test valve' and any auxiliary drain valves.
5. The pressure gauge on system side indicates now same pressure as on the water supply side (or greater).
6. Open the water supply main control valve now fully.
7. Confirm that all valves are in the normal operating positions:
 - * Alarm line ball valve (N°26) : OPEN
 - * Water supply main valve : OPEN
 - * System main drain valve (N°4) : CLOSED
 - * System test valve (N°25) : CLOSED
8. Open the alarm test ball valve (N°25) to check if the alarm is activated in less than 1 minute. After the test close this valve (N°25).
9. The valve is now in service.

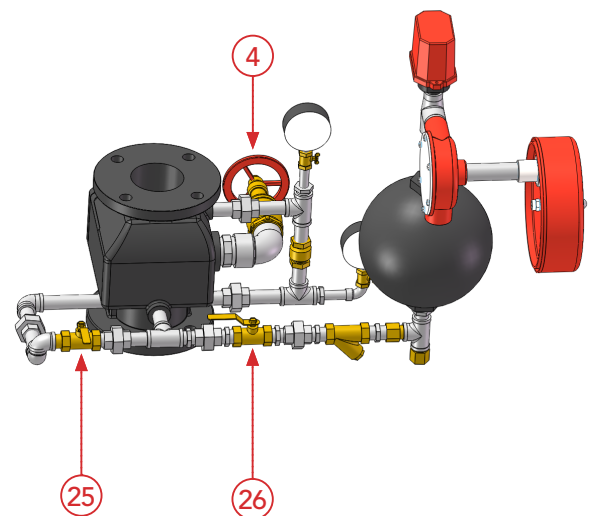



Maintenance

- AVAILABLE SPARE PART SETS:
 - Water motor gong set WMG
 - Brass bypass check valve 1/2": DCV-1/2"
 - Pressure gauge: PF0-25-1/4" - FM PROFIT
 - Maintenance set: MS-WV... :
 - 1 x EPDM disc seat gasket
 - 1 x EPDM cover-gasket
 - 1 x bolt
 - 1 x washer
 - 1 x spring washer
 - 3 x gasket for UNION-coupling (trimset)

- REPLACE CLAPPER / CLAPPER GASKET:
 - Notify the relevant instances that the alarm post will be taken out of service.
 - Close the main water supply valve.
 - Drain the system.
 - When fully drained, remove the cover: loose the 4 cover-bolts and remove cover and cover-gasket.
 - Remove the shaft, spring and clapper assembly from the valve.
 - Unscrew the clapper bolt , remove seat retainer and clapper gasket
 - Fit the new clapper gasket in place, then install the seat retainer, spring washer and tighten the bolt (see table).

Valve size	Torque Nm
3" - DN 80	25
4" - DN 100	25
6" - DN 150	25
8" - DN 200	25

- Before re-installing the clapper: check the valve-seat. Remove all dirt on deposits from the central chamber, clean also the small drain-orifices in the central chamber.
- Check if the seat surface is clean, install the clapper assembly back on the seat.
- Reinstall the spring and shaft.
- Reposition the cover with gasket. Check if the gasket is in good condition. We advise to use some silicongrease or similar to keep it in the correct position on the inside of the cover.
- Reinstall the cover and tighten the cover bolts.
- The cover gasket is o-ring shaped. For easy assembly, use small amount of grease to keep it into the groove of the cover. The o-ring should nicely fit the groove in the cover.
- Push the cover with gasket against the body while aligning the bolt holes with the threaded holes in the body.
- Insert two cover bolts and tighten up, so the cover stays in place (and gasket secured).
- Now put the remaining bolts and tighten all at the correct maximum torque value (see table).

Valve size	Torque Nm
3" - DN 80	45
4" - DN 100	45
6" - DN 150	45
8" - DN 200	110

- Put the valve back in service.

COUPLING INSTALLATION INSTRUCTIONS

GENERAL INFO - BEFORE YOU START INSTALLING THE COUPLING

- Installers should be trained or experienced to install and understand the product.
- Read and understand all technical datasheets and installation instructions before attempting to install, remove or adjust any Profit piping products.
- Depressurise and drain the sprinkler installation system before attempting to install, remove or adjust any Profit piping products.
- Never work on piping systems that are pressurised and / or filled with water.
- Piping Logistics reserves the right to change specifications, designs and / or standard equipment without notice and without incurring in any obligations.
- Use the necessary Personal Protection Equipment (PPE) to avoid personal injury (helmet, safety shoes and goggles, Profit gloves).



- Use appropriate tooling:
 - Profit groove meter and / or center punch tool
 - Impact-wrench and torque-wrench
 - Correct socket size and depth:

Bolt size	Recommended torque	Socket
	Nm	mm
M8 (1/4)	25-30	13
M10 (3/8)	44-54	15
M12 (1/2)	90-100	18
M14 (9/16)	135-150	21
M16 (5/8)	200-230	24
M20 (3/4)	270-300	30

Failure to follow these instructions could result in death or serious injury and property damage.

We advise to always store our products in closed and dry environments, the products do not need any specific maintenance once installed on an aboveground sprinkler installation.

INSTALLATION INSTRUCTIONS

1 Check the end of the pipe, after the groove, to make sure that there are no bumps, holes or loose coating particles. Remove these first, in order to prevent leaks. Always check the rubber gasket to ensure that it is suitable for the intended service.



2 The outer diameter of the housing and the groove diameter must match the specifications provided by Profit; please review the page with groove specifications.

3 Unscrew the pre-assembled coupling using an impact wrench.



4 Apply PROFIT lubricant onto the sealing lips of the gasket. Also apply lubricant to the interior side of the housings.



5 Slide the gasket over the end of the pipe and make sure that it covers the end completely.

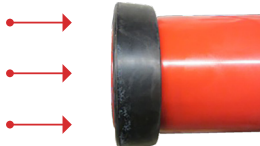

6 Bring the two pipe ends together without misalignments and pull the gasket over the end of the pipe. Make sure that the gasket is in the middle and that it covers both pipe ends.

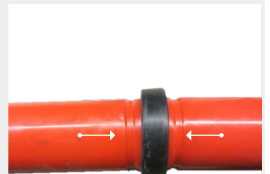

7 Place one coupling shell around the gasket. Once it is placed over the gasket, you shall see that the housing fits in the groove.



8 Stick a bolt through the housing. Make sure that the head of the bolt perfectly fits in the housing.



9 Place the second housing over the bolt and turn the nut finger-tight on the bolt. Then place the second bolt and tighten it finger-tight.

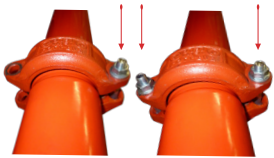

10 Tighten the bolts alternately using an impact wrench with suitable socket wrench until the coupling is completely closed. For proper sealing, bolt-torque standards must be respected (see table). A torque too big cannot improve the sealing property of the coupling; on the contrary it may damage the bolts and/or the housing and can even cause disconnection of the pipes. A torque too small will lead to leakage.



REVISION TABLE

Date	△	Notes
11/03/2024		Page 11 - Torque value has been added.
11/03/2024		Page 11 - Torque value has been added.
23/04/2024		Page 1 - Pressure switch has been added in the pictures.
13/05/2024	B	Page 5 - Addition of the trim-set dimensions of the GACV.
20/11/2024	A	Page 1 - New product picture of the FACV.