

Size range: 2" - 12"



Profit check valves type GCV are swing-type valves that allow water flow in one direction. They have a grooved in-and outlet and for installation we recommend the use of two Profit mechanical couplings. The valves are designed to be used in fire protection sprinkler systems.

**Characteristics**

- In- and outdoor use.
- Resilient seating. The swing-disc is fully encapsulated with EPDM-rubber.
- Spring loaded disc for fast closure and to minimize water hammer.
- Grooved ends according to AWWA C606 standard.
- Including two plugged drain connections.
- Installation in vertical flow (upwards) and horizontal pipes is allowed.
- Installation by use of two rigid or flexible couplings.
- Very low pressure losses, even at high flow rates.
- Anti-corrosion protection: high grade polyester powder coating RAL 3000, meets or exceeds AWWA C550 standards.

**Working pressure**

2,07 MPa / 20,7 bar / 300 psi.

**Approvals**

- FM approved to FM standard 1210.
- UL 1091 listed.
- EAC certified.

**Working temperature**

- +1°C to +87°C.

**Material specifications**

Part	Material	European standard	ASTM standard
Body	Ductile cast iron	EN-GJS-450-10	A 536 gr 65-45-12
Seat ring	Bronze	CuZn36Pb3	B62 C83600
Disc	Ductile cast iron + EPDM covered	EN-GJS-450-10	A 536 gr 65-45-12
Spindle	Stainless steel	X5CrNi18-10	AISI 304
Spring	Stainless steel	X5CrNi18-10	AISI 304
Plug	Stainless steel	X5CrNi18-10	AISI 304
Washer	EPDM rubber	/	D2000

**Dimensions**

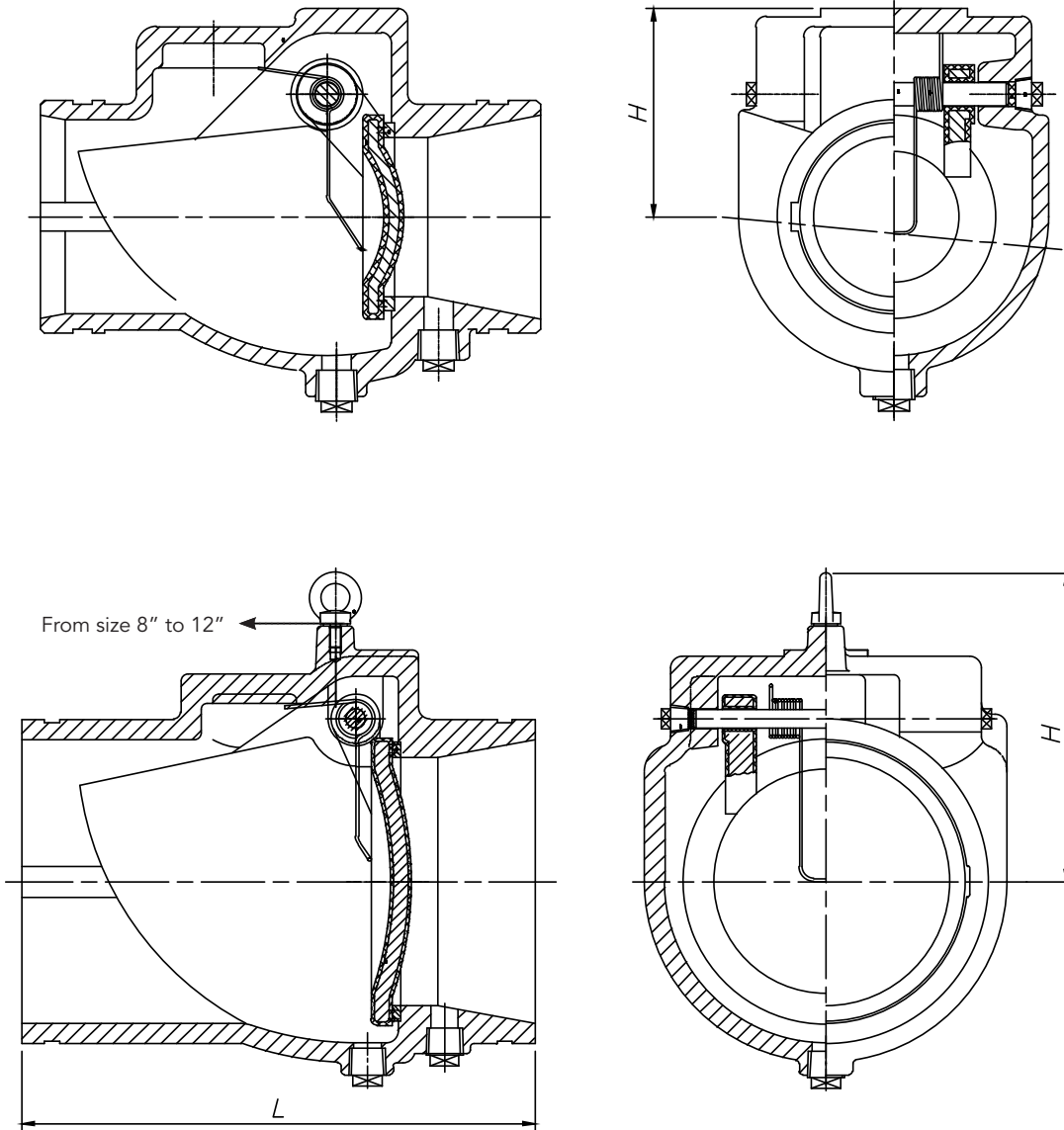

Dimensions (mm / inch)			
Size	L	H	Weight kg
2"	190 / 7,5	66 / 2,5	2,70
2,5"	203 / 8,0	75 / 3,0	3,90
3"	213 / 8,38	90 / 3,5	5,00
4"	245 / 9,65	105 / 4,0	9,30
5"	267 / 10,5	115 / 4,5	15,50
6"	292 / 11,5	140 / 5,5	19,50
8"	356 / 14,0	225 / 8,9	34,50
10"	432 / 17,0	260 / 10,2	44,00
12"	495 / 19,5	285 / 11,2	94,00

**Marking**

Body:

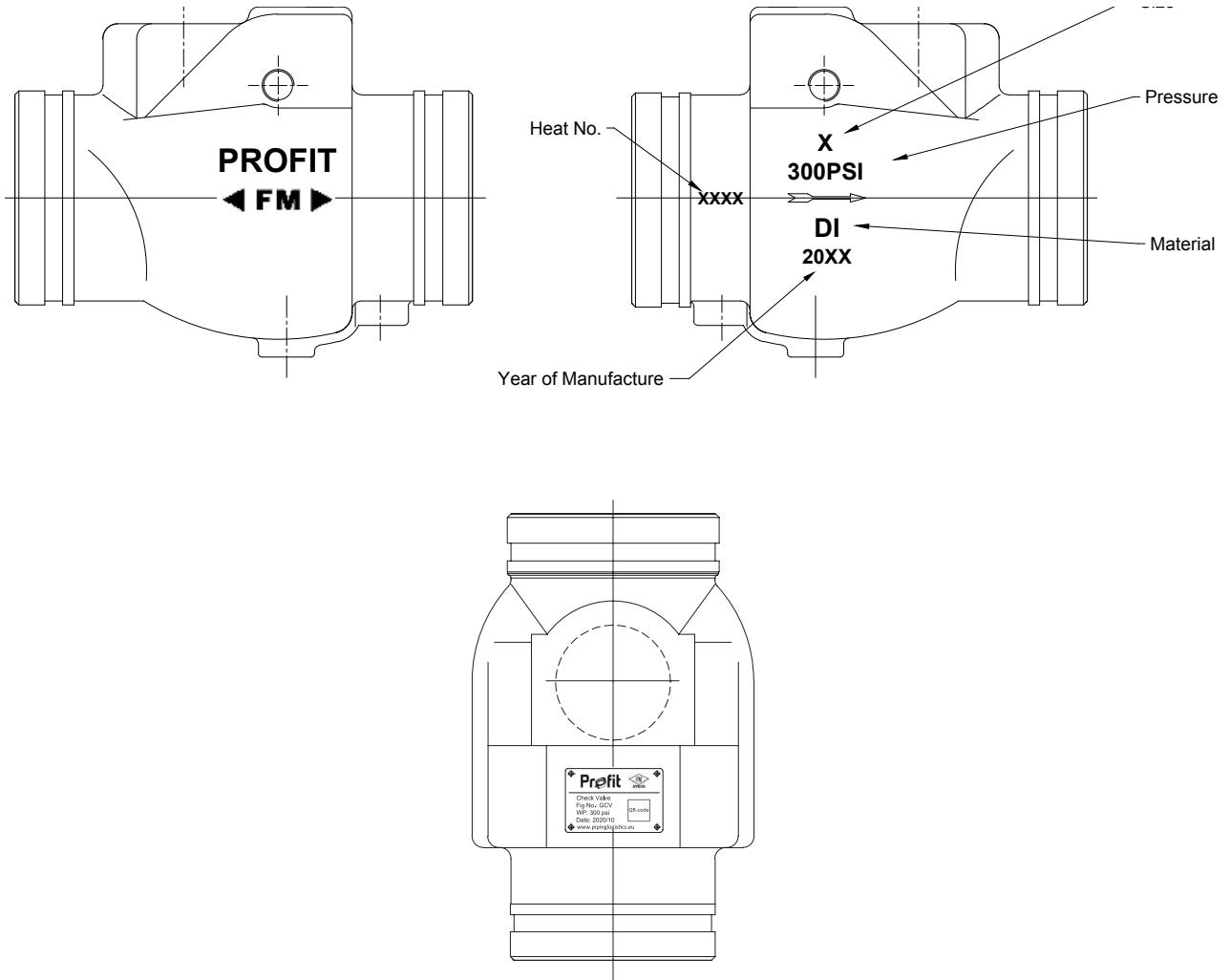

Marking-plate:

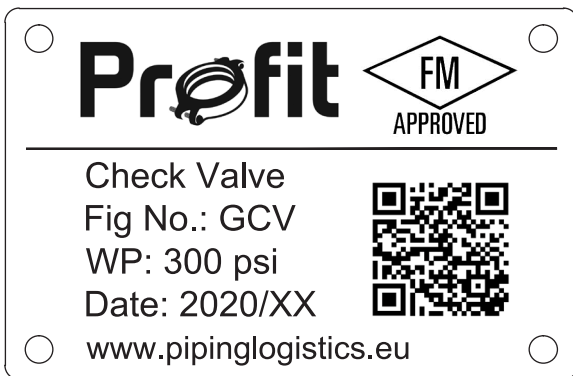

**Pressure drop charts**

[DN50 Test Report]

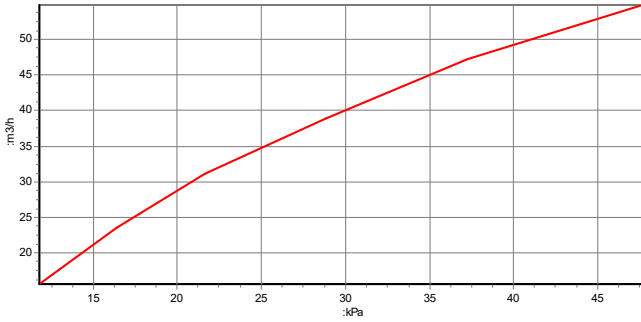

[DN65 Test Report]

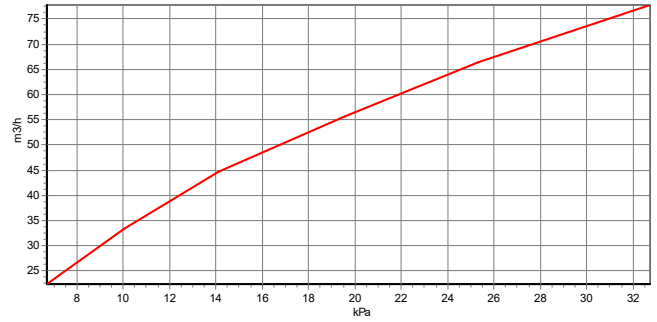

[DN80 Test Report]

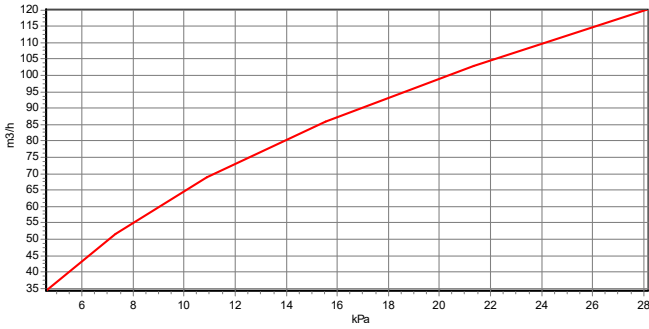

[DN100 Test Report]

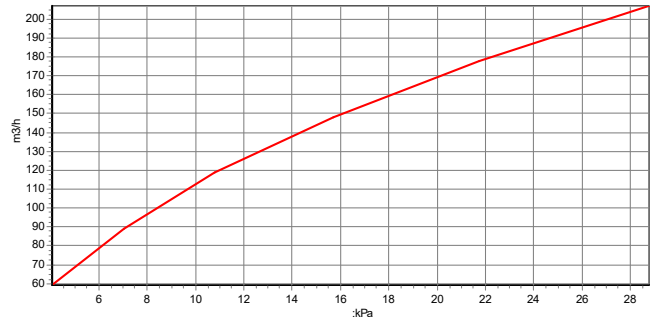

[DN150 Test Report]

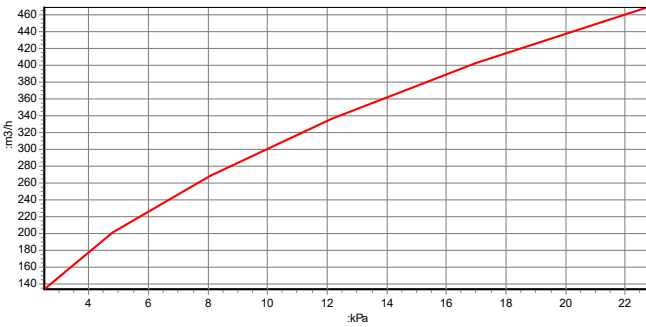

[DN200 Test Report]

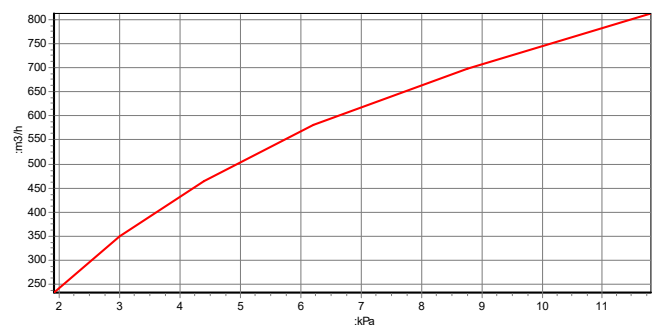

[DN250 Test Report]

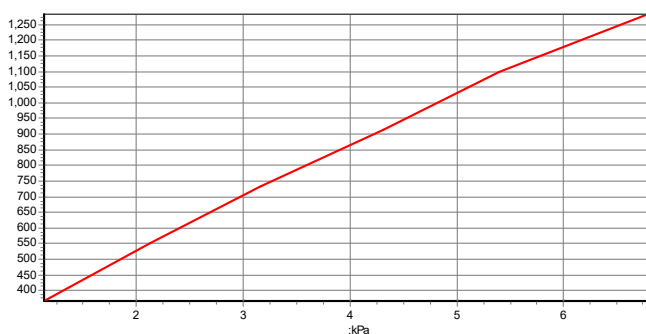

[DN300 Test Report]

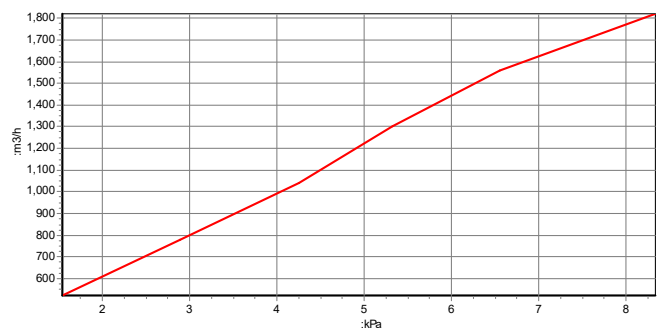

### Certifications

Size		FM
DN 50	2"	Up to 2,07 MPa / 20,7 bar / 300 psi
DN 65	2,5"	Up to 2,07 MPa / 20,7 bar / 300 psi
DN 80	3"	Up to 2,07 MPa / 20,7 bar / 300 psi
DN 100	4"	Up to 2,07 MPa / 20,7 bar / 300 psi
DN 125	5"	Up to 2,07 MPa / 20,7 bar / 300 psi
DN 150	6"	Up to 2,07 MPa / 20,7 bar / 300 psi
DN 200	8"	Up to 2,07 MPa / 20,7 bar / 300 psi



### Storage and handling

- Upon receipt, carefully check the valve-body on any damage during shipment.
- Valves should unloaded carefully , they should not be lifted or by using the waterway-passage through the valve. Do not drop onto the ground.
- GCV valves must be stored indoor, protected the rubber seating from direct sunlight. When stored outside, protect the valve from weather conditions and avoid accumulation of water, dirt, or debris.



### Installation

- Inspection before installation. Checklist:
  1. Check pressure rating of the valve is compatible with the service conditions. GCV valves may be installed with any schedule or pressure class of pipe that is listed or approved.
  2. No need to lubricate the clapper-hinges or the rubber seating inside.
  3. Check that valve-body and adjacent pipes are clean inside and that the grooves are clean and free of dust / debris.
  4. Pipework must be supported near the valve and pipes must be well aligned so that no extra stress will be exerted on the valve-body during installation.
  5. To prolong the valve-life, we recommend to install the valve not closer than 5-6 x DN when installed downstream near fittings (bends,tees, reducers, pumps etc...).

6. Check the groove dimension (with groove-gauge) in the adjacent pipework.

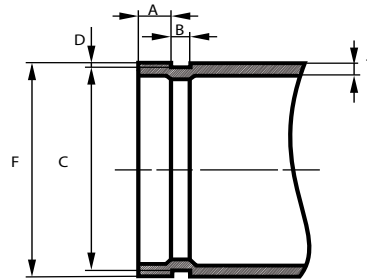

Nominal pipe size		Outside diameter			Gasket seat A	Groove width B	Groove diameter C		Groove depth* D	Maximum outspread F
NPS (DN)	Size mm	+ mm	- mm	Tolerance +0,4 / -0,8 mm	Tolerance +0,8 / -0,4 mm	Size	Tolerance mm	mm	mm	
1	25	33,7	0,41	0,68	15,9	7,1	30,2	+0/-0,3	1,6	34,5
1¼	32	42,4	0,50	0,60	15,9	7,1	39,0	+0/-0,4	1,6	43,3
1½	40	48,3	0,44	0,52	15,9	7,1	45,1	+0/-0,4	1,6	49,4
2	50	60,3	0,61	0,61	15,9	8,7	57,2	+0/-0,4	1,6	62,2
2½	65	76,1	0,76	0,76	15,9	8,7	72,3	+0/-0,4	2,0	77,7
3	80	88,9	0,89	0,79	15,9	8,7	84,9	+0/-0,4	2,0	90,6
4	100	114,3	1,14	0,79	15,9	8,7	110,1	+0/-0,5	2,2	116,2
5	125	139,7	1,40	0,79	15,9	8,7	135,5	+0/-0,5	2,2	141,7
6	150	168,3	1,60	0,79	15,9	8,7	164,0	+0/-0,6	2,2	170,7
8	200	219,1	1,60	0,79	19,1	11,9	214,4	+0/-0,6	2,4	221,5
10	250	273,0	1,60	0,79	19,1	11,9	268,3	+0/-0,7	2,4	275,4
12	300	323,9	1,60	0,79	19,1	11,9	318,3	+0/-0,8	2,8	328,2

\*According to standard AWWA C606-06

- The valves have a flow direction to be respected at installation. There is a clear flow direction arrow on the body. In vertical pipes the flow MUST always be upwards.
- In horizontal pipes please locate the hinge-pin on the top.
- For replacements: all pipes need to be depressurized and purged before starting the installation.
- Personnel for the installation must be qualified for the task.

• Installation of the valve:

Please check the couplings installation instructions; for Profit mechanical couplings the instructions are included in this datasheet (see page 7 & 8).



**Maintenance**

- GCV valves are basically installed maintenance-free. When a major problem of any kind occurs, please contact the technical dpt. of Piping Logistics.

**INSTALLATION INSTRUCTIONS**

**1** Check the end of the pipe, after the groove, to make sure that there are no bumps, holes or loose coating particles. Remove these first, in order to prevent leaks. Always check the rubber gasket to ensure that it is suitable for the intended service.



**2** The outer diameter of the housing and the groove diameter must match the specifications provided by Profit; please review the page with groove specifications.

**3** Unscrew the pre-assembled coupling using an impact wrench.



**4** Apply PROFIT lubricant onto the sealing lips of the gasket. Also apply lubricant to the interior side of the housings.



**5** Slide the gasket over the end of the pipe and make sure that it covers the end completely.

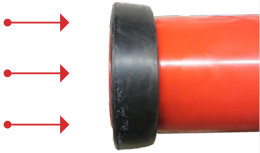

**6** Bring the two pipe ends together without misalignments and pull the gasket over the end of the pipe. Make sure that the gasket is in the middle and that it covers both pipe ends.



**7** Place one coupling shell around the gasket. Once it is placed over the gasket, you shall see that the housing fits in the groove.



**8** Stick a bolt through the housing. Make sure that the head of the bolt perfectly fits in the housing.



**9** Place the second housing over the bolt and turn the nut finger-tight on the bolt. Then place the second bolt and tighten it finger-tight.

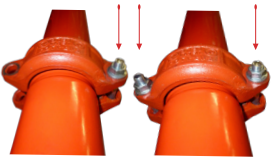

**10** Tighten the bolts alternately using an impact wrench with suitable socket wrench until the coupling is completely closed. For proper sealing, bolt-torque standards must be respected (see table). A torque too big cannot improve the sealing property of the coupling; on the contrary it may damage the bolts and/or the housing and can even cause disconnection of the pipes. A torque too small will lead to leakage.



**GENERAL INFO - BEFORE YOU START**

- Installers should be trained or experienced to install and understand the product.
- Read and understand all technical datasheets and installation instructions before attempting to install, remove or adjust any Profit piping products.
- Depressurise and drain the sprinkler installation system before attempting to install, remove or adjust any Profit piping products.
- Never work on piping systems that are pressurised and / or filled with water.
- Piping Logistics reserves the right to change specifications, designs and / or standard equipment without notice and without incurring in any obligations.
- Use the necessary Personal Protection Equipment (PPE) to avoid personal injury (helmet, safety shoes and goggles, Profit gloves).



- Use appropriate tooling:
- Profit groove meter and / or center punch tool
- Impact-wrench and torque-wrench
- Correct socket size and depth:

Bolt size	Recommended torque	Socket
	Nm	mm
M8 (¼)	25-30	13
M10 (⅜)	44-54	15
M12 (½)	90-100	18
M14 (⅝)	135-150	21
M16 (⅞)	200-230	24
M20 (¾)	270-300	30

**Failure to follow these instructions could result in death or serious injury and property damage.**

**We advise to always store our products in closed and dry environments, the products do not need any specific maintenance once installed on an aboveground sprinkler installation.**

**REVISION TABLE**

Date	△	Notes
14/06/2024	A	Page 1 - The approvals have been added.