

**Size range: 2-1¼" - 8-4"**  
THREADED BSPT OUTLET

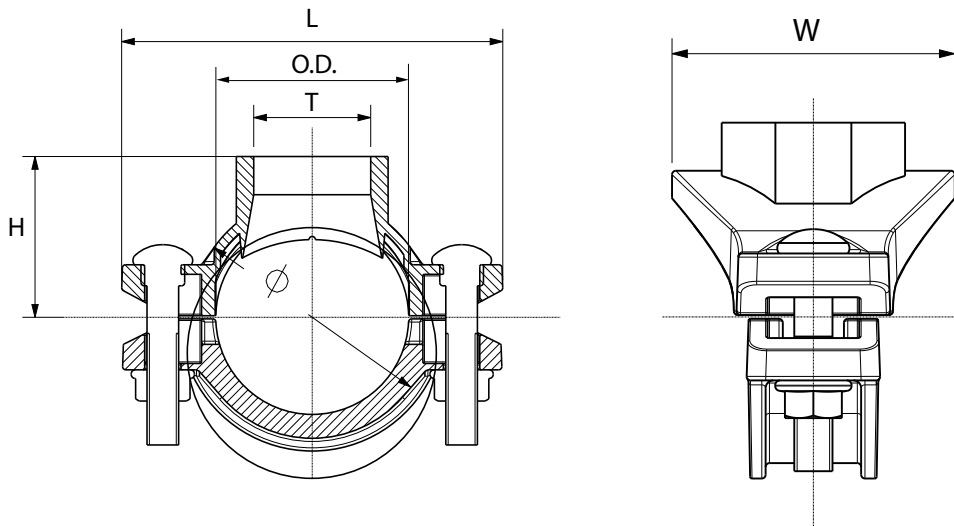

Threaded mechanical tees may be used for any tee connection where a threaded outlet is needed. Some sizes may be converted into a cross when necessary\*\*.

\*\*Mechanical cross not FM and UL certified.



**Material specifications**

**Housing:** ductile iron conform to ASTM A536 GR65-45-12

**Coating:**

- Hot dip galvanised
- Red paint coating RAL 3000, EPD epoxy coating (any other colour on request).

**Rubber gaskets:** EPDM gaskets dispose of the international certifications and have undergone the aging test at 110°C/230°F during a period of 45 days/1080 hours and the frozen test at -40°C/-40°F during a period of 4 days/96 hours.

**Bolts and nuts:** see technical datasheet bolts and nuts.

**Working pressure**

300 psi / 2068 kPa

**Approvals**

- FM approved - FM 1920
- UL listed - UL 213
- CNBOP approved

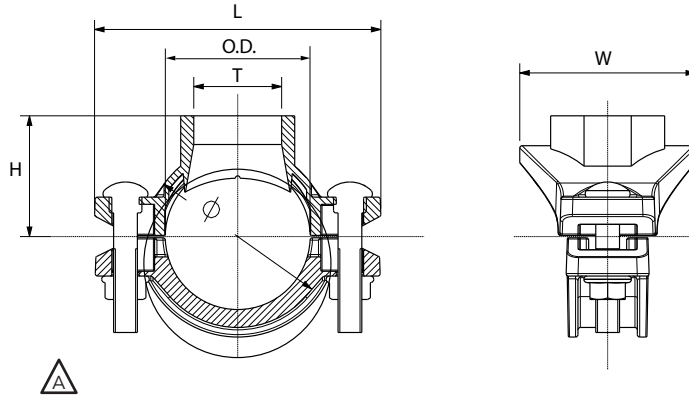

Reference		Nominal size Run - reducing outlet		Pipe $\phi$ O.D. - T	Threaded mechanical tee dimensions				Hole cut*	Bolt size	Socket wrench	Bolt torque	Weight	Marking
Red	Galva	NPS inch	DN mm	mm-inch	L mm	H mm	W mm	$\phi$ mm	mm	d1xL mm	mm	Nm	kg	
GMDR	GMDG	2-1¼	50-32	60,3 - 1¼	120	55	76	85	46+1	M10x50	15	44-54	0,86	GMD
GMDR	GMDG	2-1½	50-40	60,3 - 1½	120	63	76	85	46+1	M10x50	15	44-54	0,95	GMD
GMDR	GMDG	2½-1¼	65-32	73,0 - 1¼	139	60	76	99	46+1	M10x60	15	44-54	0,96	GMD
GMDR	GMDG	2½-1½	65-40	73,0 - 1½	139	60	85	99	53+1	M10x60	15	44-54	0,99	GMD
GMDR	GMDG	2½-1¼	65-32	76,1 - 1¼	139	60	76	99	46+1	M10x60	15	44-54	0,96	GMD
GMDR	GMDG	2½-1½	65-40	76,1 - 1½	139	60	83	99	53+1	M10x60	15	44-54	0,99	GMD
GMDR	GMDG	2½-2	65-50	76,1 - 2	139	60	80	99	64+1	M10x60	15	44-54	1,20 <sup>3)</sup>	GMD
GMDR	GMDG	3-½	80-15	88,9 - ½	155	67	55	107	30+1	M10x60	15	44-54	0,88	GMD
GMDR	GMDG	3-¾	80-20	88,9 - ¾	155	67	55	107	30+1	M10x60	15	44-54	0,88	GMD
GMDR	GMDG	3-1	80-25	88,9 - 31	155	67	66	113	38+1	M10x60	15	44-54	0,99	GMD
GMDR	GMDG	3-1¼	80-32	88,9 - 1¼	155	67	73	113	46+1	M10x60	15	44-54	1,04	GMD
GMDR	GMDG	3-1½	80-40	88,9 - 1½	155	67	82	113	53+1	M10x60	15	44-54	1,10	GMD
GMDR	GMDG	3-2	80-50	88,9 - 2	155	67	92	113	64+1	M10x60	15	44-54	1,23	GMD
GMDR	GMDG	3-2½	80-65	88,9 - 2½	155	67	117	133	64+1	M10x60	15	75-80	1,90 <sup>3)</sup>	GMD
GMDR	GMDG	4-½	100-15	114,3 - ½	181	79	70	139	38+1	M12x70	18	90-100	1,44 <sup>3)</sup>	GMD
GMDR	GMDG	4-¾	100-20	114,3 - ¾	181	79	70	139	38+1	M12x70	18	90-100	1,44 <sup>3)</sup>	GMD
GMDR	GMDG	4-1	100-25	108,0 - 1	172	77,5	66	132	38+1	M12x70	18	90-100	1,22 <sup>2)</sup>	GMD
GMDR	GMDG	4-1¼	100-32	108,0 - 1¼	172	77,5	73	132	46+1	M12x70	18	90-100	1,30 <sup>2)</sup>	GMD
GMDR	GMDG	4-1½	100-40	108,0 - 1½	172	77,5	79	132	53+1	M12x70	18	90-100	1,35 <sup>2)</sup>	GMD
GMDR	GMDG	4-2	100-50	108,0 - 2	172	78,5	91	132	64+1	M12x70	18	90-100	1,47 <sup>2)</sup>	GMD
GMDR	GMDG	4-1	100-25	114,3 - 1	181	79	70	139	38+1	M12x70	18	90-100	1,22	GMD
GMDR	GMDG	4-1¼	100-32	114,3 - 1¼	181	79	78	139	46+1	M12x70	18	90-100	1,24	GMD
GMDR	GMDG	4-1½	100-40	114,3 - 1½	181	79	83	139	53+1	M12x70	18	90-100	1,31	GMD
GMDR	GMDG	4-2	100-50	114,3 - 2	181	79	96	139	64+1	M12x70	18	90-100	1,40	GMD
GMDR	GMDG	4-2½	100-65	114,3 - 2½	181	100	117	138	70+1	M12x70	18	90-100	1,96	GMD
GMDR	GMDG	4-2½	100-65	114,3 - 2½	181	100	117	138	70+1	M12x70	18	90-100	1,96	GMD
GMDR	GMDG	4-3	100-80	114,3 - 3	181	101	130	138	89+1	M12x70	18	90-100	1,70 <sup>3)</sup>	GMD
GMDR	GMDG	5-1	125-25	133,0 - 1	205	88	66	158	38+1	M12x75	18	90-100	1,74 <sup>2)</sup>	GMD
GMDR	GMDG	5-1¼	125-32	133,0 - 1¼	205	88	75	158	46+1	M12x75	18	90-100	1,83 <sup>2)</sup>	GMD
GMDR	GMDG	5-1½	125-40	133,0 - 1½	205	88	81	158	53+1	M12x75	18	90-100	1,86 <sup>2)</sup>	GMD
GMDR	GMDG	5-2	125-50	133,0 - 2	205	88	93	158	64+1	M12x75	18	90-100	1,90 <sup>2)</sup>	GMD
GMDR	GMDG	5-1	125-25	139,7 - 1	212	92,5	66	167	38+1	M12x75	18	90-100	1,61	GMD
GMDR	GMDG	5-1¼	125-32	139,7 - 1¼	212	92,5	72	167	46+1	M12x75	18	90-100	1,60	GMD
GMDR	GMDG	5-1½	125-40	139,7 - 1½	212	92,5	80	167	53+1	M12x75	18	90-100	1,70	GMD
GMDR	GMDG	5-2	125-50	139,7 - 2	212	92,5	91	167	64+1	M12x75	18	90-100	1,82	GMD
GMDR	GMDG	5-2½	125-65	139,7 - 2½	219	115	117	168	70+1	M16x85	24	200-230	2,60 <sup>1)</sup>	GMD
GMDR	GMDG	5-2½	125-65	139,7 - 2½	219	115	117	168	70+1	M16x85	24	200-230	2,60 <sup>1)</sup>	GMD



Reference		Nominal size Run - reducing outlet		Pipe Ø O.D. - T	Threaded mechanical tee dimensions				Hole cut*	Bolt size	Socket wrench	Bolt torque	Weight	Marking
Red	Galva	NPS inch	DN mm	mm-inch	L mm	H mm	W mm	Ø mm	mm	d1xL mm	mm	Nm	kg	
GMDR	GMDG	5-3	125-80	139,7 - 3	219	118	136	168	89+1	M16x85	24	200-230	2,48 <sup>3)</sup>	GMD
GMDR	GMDG	5-1	125-25	141,3 - 1	212	92,5	66	167	38+1	M12x75	18	90-100	1,70	GMD
GMDR	GMDG	5-1¼	125-32	141,3 - 1¼	212	92,5	75	167	46+1	M12x75	18	90-100	1,75	GMD
GMDR	GMDG	5-1½	125-40	141,3 - 1½	212	92,5	81	167	53+1	M12x75	18	90-100	1,77	GMD
GMDR	GMDG	5-2	125-50	141,3 - 2	212	92,5	93	167	64+1	M12x75	18	90-100	2,02	GMD
GMDR	GMDG	5-2½	125-65	141,3 - 2½	219	115	117	168	70+1	M16x85	24	200-230	2,60	GMD
GMDR	GMDG	5-2½	125-65	141,3 - 2½	219	115	117	168	70+1	M16x85	24	200-230	2,60	GMD
GMDR	GMDG	5-3	125-80	141,3 - 3	219	118	136	168	89+1	M16x85	24	200-230	2,48 <sup>3)</sup>	GMD
GMDR	GMDG	6-1	150-25	159,0 - 1	236	102	66	184	38+1	M16x85	24	200-230	2,18 <sup>3)</sup>	GMD
GMDR	GMDG	6-1¼	150-32	159,0 - 1¼	236	102	72	184	46+1	M16x85	24	200-230	2,20 <sup>3)</sup>	GMD
GMDR	GMDG	6-1½	150-40	159,0 - 1½	236	102	80	184	53+1	M16x85	24	200-230	2,23 <sup>3)</sup>	GMD
GMDR	GMDG	6-2	150-50	159,0 - 2	236	102	91	184	64+1	M16x85	24	200-230	2,25 <sup>3)</sup>	GMD
GMDR	GMDG	6-1	150-25	165,1 - 1	248	106	66	191	38+1	M16x85	24	200-230	2,25	GMD
GMDR	GMDG	6-1¼	150-32	165,1 - 1¼	248	106	73	191	46+1	M16x85	24	200-230	2,30	GMD
GMDR	GMDG	6-1½	150-40	165,1 - 1½	248	106	79	191	53+1	M16x85	24	200-230	2,28	GMD
GMDR	GMDG	6-2	150-50	165,1 - 2	248	106	91	191	64+1	M16x85	24	200-230	2,36	GMD
GMDR	GMDG	6-2½	150-65	165,1 - 2½	248	125	117	191	70+1	M16x85	24	200-230	3,02	GMD
GMDR	GMDG	6-2½	150-65	165,1 - 2½	248	125	117	191	70+1	M16x85	24	200-230	3,02	GMD
GMDR	GMDG	6-3	150-80	165,1 - 3	248	124	137	191	89+1	M16x85	24	200-230	3,18 <sup>3)</sup>	GMD
GMDR	GMDG	6-4	150-100	165,1 - 4	248	128	163	191	114+1	M16x85	24	200-230	4,70 <sup>3)</sup>	GMD
GMDR	GMDG	6-1	150-25	168,3 - 1	248	106	69	196	38+1	M16x85	24	200-230	2,16	GMD
GMDR	GMDG	6-1¼	150-32	168,3 - 1¼	248	106	72	196	46+1	M16x85	24	200-230	2,36	GMD
GMDR	GMDG	6-1½	150-40	168,3 - 1½	248	106	85	196	53+1	M16x85	24	200-230	2,36	GMD
GMDR	GMDG	6-2	150-50	168,3 - 2	248	106	90	196	64+1	M16x85	24	200-230	2,43	GMD
GMDR	GMDG	6-2½	150-65	168,3 - 2½	248	128	117	194	70+1	M16x85	24	200-230	3,02	GMD
GMDR	GMDG	6-2½	150-65	168,3 - 2½	248	128	117	194	70+1	M16x85	24	200-230	2,34	GMD
GMDR	GMDG	6-3	150-80	168,3 - 3	248	131	136	194	89+1	M16x85	24	200-230	3,18 <sup>3)</sup>	GMD
GMDR	GMDG	6-4	150-100	168,3 - 4	248	135	166	196	114+1	M16x85	24	200-230	4,70 <sup>3)</sup>	GMD
GMDR	GMDG	8-1	200-25	219,1 - 1	311	134	73	248	38+1	M16x85	24	200-230	-	GMD
GMDR	GMDG	8-1¼	200-32	219,1 - 1¼	311	134	83	248	46+1	M16x85	24	200-230	3,10	GMD
GMDR	GMDG	8-1½	200-40	219,1 - 1½	311	134	89	248	53+1	M16x85	24	200-230	3,18	GMD
GMDR	GMDG	8-2	200-50	219,1 - 2	311	137,5	93	247	64+1	M16x85	24	200-230	3,25	GMD
GMDR	GMDG	8-2½	200-65	219,1 - 2½	322	154	117	253	70+1	M20x90	30	270-300	3,75	GMD
GMDR	GMDG	8-2½	200-65	219,1 - 2½	322	154	117	253	70+1	M20x90	30	270-300	3,75	GMD
GMDR	GMDG	8-3	200-80	219,1 - 3	322	167	136	253	89+1	M20x90	30	270-300	4,16 <sup>2)</sup>	GMD
GMDR	GMDG	8-4	200-100	219,1 - 4	322	167	162	253	114+1	M20x90	30	270-300	6,10 <sup>3)</sup>	GMD

<sup>1)</sup> No FM-approval / <sup>2)</sup> No UL-approval / <sup>3)</sup> No FM- and UL-approval.

**LABEL EXAMPLE**

Mechanical tee GMD (Threaded)	
2-11/4	3-11/4
2-11/2	4-11/4
21/2-11/4	6-11/4
Hole cut dimension 46(+1mm)	

- \* Please note that the **correct hole cut dimension** is mentioned:
- on the label which is attached to the product itself
  - on the document called 'Hole cut dimensions', which is added to each delivery from our warehouse Piping Logistics, Belgium. This document is attached to the outside of the first box in a plastic pouch with reference 'Documents enclosed'

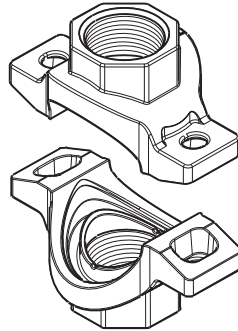

Mechanical cross** conversion				
Inch	Main pipe diameter		Maximum outlet mechanical cross	
	DN mm	O.D. mm	DN mm	Thread size T
2½	65	76,1	32	1¼"
3	80	88,9	40	1½"
4	100	114,3	50	2"
6	150	168,3	80	3"
8	200	219,1	100	4"

\*\*Mechanical cross not FM and UL certified.

**GENERAL INFO**

- Installers should be trained or experienced to install and understand the product.
- Read and understand all technical datasheets and installation instructions before attempting to install, remove or adjust any Profit piping products.
- Depressurize and drain the sprinkler installation system before attempting to install, remove or adjust any Profit Piping products.
- Never work on piping-systems that are pressurized and /or filled with water.
- Use the necessary Personal Protection Equipment (PPE) to avoid personal injury (helmet, safety shoes and goggles, Profit gloves).



- Profit reserves the right to change specifications, designs and/or standard equipment without notice and without incurring in any obligations.
- Profit red coated products are intended for piping with indoor application (EN 12944-2 corrosivity category C1 & C2). For outdoor installations near the sea (corrosivity category C3) we advise the use of our hot dip galvanized couplings and fittings. For application in corrosivity category C4 (higher salinity climate) or higher, please contact info@pipinglogistics.eu.
- Pressure ratings listed are CWP (cold working pressure) or MWP (maximum working pressure) at a maximum service temperature of 50°C. This rating may occasionally differ from maximum working pressure listed and/or approved by UL and/or FM, as testing conditions and test pipes can differ. For more information, please contact info@pipinglogistics.eu.
- Maximum working pressure listed is the total of internal and external pressures based on standard weight (ANSI) steel pipe and standard roll or cut groove in accordance with Profit specifications. For more information, please contact info@pipinglogistics.eu.
- For one time field test only, the maximum joint working pressure may be increased by 150% the figure shown.

**Failure to follow these instructions could result in death or serious injury and property damage.**

**We advise to always store our products in closed and dry environments, the products do not need any specific maintenance once installed on an aboveground sprinkler installation.**

**REVISION TABLE**

Date	△	Notes
01/03/2024	A	Page 2 & 3 - inch added in table